

# Smart Home

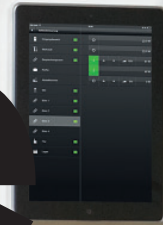

Innovative Building Automation –  
At Home or on the Road

ubisys®





# **Smart Home**

Innovative Building Automation –  
At Home or on the Road

Product Catalog 2020/21

# Content

<b>Introduction</b>	<b>8</b>	<b>Lighting and consumers</b>	<b>48</b>
<b>Solutions</b>	<b>10</b>	<b>Shading</b>	<b>55</b>
Interface	12	<b>Climate</b>	<b>58</b>
Energie efficiency	14	<b>Additional options</b>	<b>67</b>
Alarm and security functions	16	<b>Compatible Zigbee products</b>	
Scheduled actions	20	<b>of other manufacturers</b>	<b>70</b>
Scenes	22	<b>Products for electrical specialists</b>	
Configuration	24	<b>and system integrators</b>	<b>76</b>
Amazon Echo	26	<b>Installation</b>	<b>82</b>
Apple HomeKit	28	<b>Technology and innovation</b>	<b>86</b>
Energy-independent push button	30	<b>Quality claim and data protection</b>	<b>90</b>
HCL: Daylight simulation	32	<b>Show house</b>	<b>94</b>
Mini-app store	34	<b>Sources of supply and contact</b>	<b>100</b>
JavaScript engine	36	<b>Imprint</b>	<b>102</b>
<b>System overview</b>	<b>38</b>		
<b>Products</b>	<b>40</b>		
Interface	42		
Gateway	45		



## **Introduction**

You want to control your entire building technology via smartphone? Or configure your home to perform tasks independently? ubisys Smart Home makes your wish for an intelligent home possible. It relieves you of tasks and makes your everyday life easier.

Your electrical devices are connected to each other wirelessly thus enabling smart operation – via existing switches, smartphone or voice control.

It does not matter whether you live in an older building or are planning a new construction, radio technology makes uncomplicated retrofitting and flexible planning possible.

ubisys Smart Home unites all important trades in one system: lighting and shading control, heating regulation and alarm features.

Integrate new solutions and devices yourself any time: create scenes, configure time-controlled events, install sensors for automation purposes or expand your system with new components any given time as necessary and within your budget.

ubisys Smart Home offers you endless possibilities to make your home smart.

### **More safety, comfort and cost control**

ubisys Smart Home offers you numerous solutions for intelligent building control. The main focus is placed on the central and decentralized control of the entire house, energy and cost efficiency, more comfort, more safety and sustainability.



## Interface With the ubisys App you have all the Functions of your System at a Glance – always and everywhere.

With the ubisys system, you can control your home centrally via an app on your smartphone or tablet, or as usual via your already installed switches. Displaying all the functions and features at a glance:

- lighting control (on/off, dimming, color ambiance)
- heating control
- shutter control (individually or in groups)
- consumer control via switchable sockets (e.g. floor lamps, kitchen appliances, irons)
- power consumption
- alarm via push messages
- many more

The complex building control is represented by easy-to-understand graphics and allows you a quick orientation. When designing the app we especially emphasized maximum user friendliness – colors, font sizes, menu navigation, buttons, etc. guarantee a simple, comfortable and intuitive operation. If you are not on site, you can also control and monitor your building while you are on the road. In addition the app is also suitable for commissioning and configuration.

The ubisys app is available for Apple iOS and Google Android.



# Energy Efficiency ubisys Smart Home Helps You Saving Energy. This not only Protects the Environment, but Effectively also Your Wallet.

With ubisys Smart Home you save money while simultaneously saving resources. With our universal dimmer D1, you not only ensure cozy feel-good lighting, but also save energy and thus reduce CO<sub>2</sub> emissions. Or simply reduce the stand-by consumption of your devices with our power switch S1.

With our solutions for heating control you also have the opportunity to utilize further savings potential. Mainly because the heating system is responsible for about 60% of the overall energy consumption in an average household. Control your heating via smartphone and set your desired temperature while on the go – or simply automate this process with our time function. Not to forget the possibility of synergy effects in conjunction with blinds, open windows, etc. This not only increases general comfort, but also ensures that no energy is wasted. Your optimized heating behavior will save you money, so that your smart heating control will pay off soon.

Another important cost control feature is power metering. All ubisys building control components have a current measuring function that allows you to measure the power consumption of

individual devices. The consumption values are displayed in the app or in our dashboard for data visualization. Allowing you to keep an eye on your energy costs, controlling and saving costs at any time.

#### Measured parameters\*):

- Effective power [W]
- Apparent power [VA]
- Reactive power [VAr]
- Power factor
- RMS value of the voltage [V]
- RMS value of the current [A]
- Instantaneous voltage over time [V]
- Instantaneous current over time [A]

\*) These parameters can be detected by the Zigbee components. Which values are actually displayed depends on the visualization solution.





## Alarm and Security Functions Do not Simply Make your Home Smart, but also Safer.



In order to make your Smart Home more secure you can not only attach sensors such as door/window contacts, motion detectors, smoke detectors, etc., but also an alarm keypad in the entrance area. The keypad is a permanently installed input device for PIN codes. Authorized persons can use it to operate the ubisys alarm system.

This alarm keypad allows for an easy way to control your ubisys alarm system. Using the action buttons and entering a personal PIN code, the status of the Smart Home system can be switched between present and out-of-the-property or it can be armed or disarmed. Illuminated buttons allow operation even in the dark. Status LEDs show the current status of the alarm system, allowing the cleaner to operate the alarm system without having to use the ubisys app.

To increase the battery life, the device has a proximity sensor. If a hand comes into its direct environment, the LED illumination of the keys will automatically switch on. This feature protects the batteries while allowing you to adjust settings even in the dark.

### A couple of features:

- Easy arming/disarming of the alarm system
- Presence control: present/on the go
- Acoustic feedback during arming, button presses and warnings



# Alarm and Security Functions If Your House Sounds Alarm in Case of Danger, You will be the First to be Informed – Even if You are not There.

ubisys Smart Home makes your house safer. Whether by sensors such as door and window contacts, motion detectors, gas and smoke detectors, leakage sensors or by random scenarios that simulate presence (check section „Scheduled Actions“). Here some examples:

## In case of fire (registered by smoke detectors)

- All smoke detectors in the house sound an alarm
- All the lights in the house are turned on
- In case of fire blinds/shutters are raised to clear the escape routes
- You will immediately receive a notification on your smartphone where the danger is located within the house

## In case of burglary (registered by door/window contacts or motion detectors)

- The blinds are automatically raised and the lights are turned on throughout the house
- You will immediately receive a notification on your smartphone







## Scheduled Actions Thanks to Timed Events your ubisys Smart Home can do a lot of Tasks on its own.

The scheduled actions option allows you to program timed events yourself. It's just as easy as setting an alarm clock. Different types of time functions are available for different tasks, which you can combine in any number of ways:

### Variation 1: Any time

Select date and time for a one-time event.

### Variation 2: Every day at a specific time

Select a time of day and set desired weekdays. You can include or exclude holidays, specify a time period for random execution (for example half an hour earlier, up to a quarter of an hour later than scheduled), and limit the validity period in the form of a first-time or last-time execution.

### Variation 3: At sunrise and sunset

Depending on the location of your system, the astronomical times for the sunrise or sunset are calculated according to the season and can be used as a basis for time control. In addition, you can specify a time offset (rather than planned, later than planned) and a time period for random execution. In addition, times of day may be indicated as a limit, e.g. not before 07:00h, not after 22:00h. Here, too, variants for different days of the week can be set up, as well as public holidays included or excluded.

### Variation 4: At regular intervals

Have an action carried out at regular intervals, e.g. every minute, every hour, every eight hours etc. Also supports variations for different days of the week, holidays, random periods and absolute limits for the times of the day (for example not before 10:00h, not after 14:00h).

At the scheduled time, scenes you have defined are called up, e.g. open or close all blinds, call up a lighting mood, switch certain devices on or off, etc.

**Examples:** During the week, public holidays exempt, raise the blinds at sunrise (but not before 06:45h) in the whole object, but keep lowered in the bedroom and only set the slats to 45°. On weekends and public holidays, this should only happen at 9:00 a.m.

Turn on and dim the lights in different rooms at the time of your vacation, randomly between half an hour before and one hour after sunset. Then switch off gradually between 10:30 p.m. and 11:45 p.m., ending in the bedroom.

The scheduled actions are not based on a cloud service and therefore work regardless of whether an internet connection is available or e.g. was temporarily disconnected.

If you ever need more than a simple time function, you can fall back on our mini-apps that allow very sophisticated automation. Very individual, tailor-made solutions can be implemented using the common and widely used programming language JavaScript. More information can be found under „Solutions/Mini-App Store“ or „Solutions/JavaScript Engine“.



# Scenes When Leaving the House, You Can Switch Everything off at the same Time with a Simple Tap. This Increases Safety and Comfort.

With this feature you can quickly and easily increase the comfort in your property. In a scene, you can determine presets for certain devices (such as dimmers and/or blinds) and activate them at the touch of a button. You can activate a scene in the app or with a switch or button in your house. Some examples:

## **Scene „Goodbye“**

You are about to leave your home. Activate the scene „Goodbye“ and all lights and unrequired consumers of your Smart Home system will be switched off, the blinds will be lowered down and the heating will be turned down.

## **Scene „Hello“**

You are back at home and want to activate several consumers at the same time? No problem with a scene „Hello“: the lights in the entrance area are switched on, the shutters are raised and the temperature increased to „comfort temperature“.

Scenes can be created quickly and easily, as well as changed and deleted at any time.







## Configuration Individual Settings of your Smart Home System can be done quickly and easily by Yourself.

In addition to simple and intuitive operation, the ubisys system also offers the option of configuring your Smart Home by yourself.

Allowing you to easily make the initial setup as well as the configuration of subsequent installations (create and name rooms, name components and place them in the corresponding rooms, etc.). The configuration is easily carried out via the ubisys app.

You can also create groups combining several components, which you then control via a switch or pushbutton (example: one shutter switch simultaneously controlling several blinds).

You can also add a scene to a button or switch (example scene „Goodbye“: A button/switch in the entrance area lowers all blinds down to 80%, all sockets are deactivated and the lights are switched off).

The possibility of individual configuration by yourself offers you maximum freedom and flexibility: You can quickly create, change and delete everything easily by yourself.



# Amazon Echo “Alexa, Dimm the Light in the Living Room at 50%.”

The Amazon Echo speaker connects to the cloud-based Alexa voice service to play music, make phone calls, set alarms and timers, view the calendar, weather, traffic and sports scores, manage to-do and shopping lists as well as compatible smart home devices and more.

With Amazon Echo, you can easily control your ubisys system by voice. Alexa is constantly learning and getting new features and skills. Some features of Amazon Echo in combination with ubisys products:

## **Dimm function**

Dimming your light via voice control with the ubisys Universal Dimmer D1.

## **Controlling groups**

Control multiple ubisys devices simultaneously by voice.

## **Scenes**

Activate your favorite scenes via voice control.

**Note:** Amazon Echo is available in different versions. In order to control your ubisys components via Alexa, you need the Amazon Echo or Echo Dot in combination with the Gateway G1 and the ubisys Skill.

The Amazon Echo Plus has a built-in Zigbee hub, so no additional hub is required. You can use it to control ubisys devices without the Gateway G1 and ubisys Skill.



# Apple HomeKit ubisys Products are Compatible with Apple HomeKit.

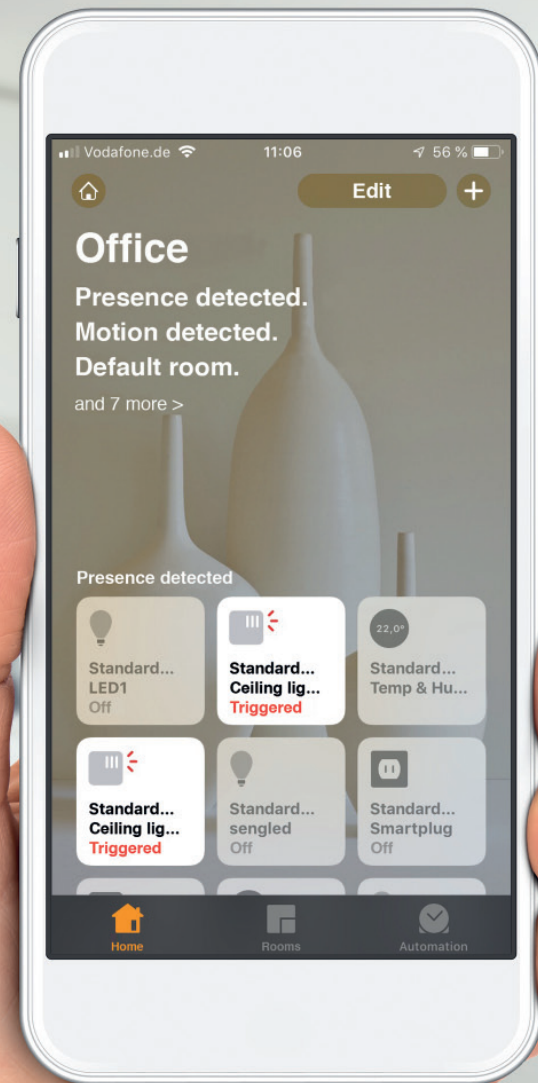

With the Apple Home app, similarly to the ubisys Smart Home app, you can easily and securely control and monitor your facility:

Since the HomeKit function is already integrated into the operating system, the devices can be controlled quickly – whether via Siri, favorites in the control center or the Home App (also on the Apple Watch).

Let Siri turn off the light from your iPhone. Check on your iPad who's at the front door. Using your Mac, comfortably adjust the temperature in the living room. Control your building from outside via Apple TV. With the Home App, all your connected devices will work better – and smarter.

Over 100 brands worldwide are committed to providing accessories that are compatible with the HomeKit framework, and the number available is growing every day. Each of these accessories is reviewed and approved by Apple to help ensure your security when you use it.

The Home app allows you to set scenes, which enable multiple accessories to work in combination – all with a single command.

Integrate ubisys products into your Apple HomeKit quickly and easily to create scenes and/or scheduled actions.



# Energy-Independent Push Button No Wires, no Battery, no Maintenance – Retrofitting doesn't get any easier than this.

This battery-free wireless pushbutton as a single or double rocker solution offers you maximum flexibility in the expansion of your ubisys Smart Home.

You can attach it anywhere in your property without any complicated installation - it can be easily glued or screwed on, no additional wiring required.

Utilising the Zigbee Green Power standard you can switch individual consumers such as lamps (via ubisys Universal dimmer D1), outlets/sockets (via ubisys S1 Power switch) or entire groups. Furthermore, the button allows the activation of scenes, as well as controlling your shutters and blinds. In addition, the pushbutton can also be linked directly to universal dimmers,

shutter controls or power switches from ubisys and works both with or without a gateway. For Zigbee devices that do not yet provide direct or sufficient support for Green Power, the Gateway G1 can also translate – allowing these buttons to be used with most common smart bulbs by major brands.

This button is completely maintenance-free – **no battery changes** are necessary, since the necessary energy is gained completely from pressing the button. And thanks to the generic profile, these are highly versatile. Especially in the commercial sector, this solution offers not to be underestimated advantages – especially in terms of cost reduction: No planning effort, minimal installation costs, retrofittable at any time.







## Human Centric Lighting (HCL) Daylight Simulation – the Right Light at the Right Time.

Daylight plays an important role in the well-being of humans. But what if it is not available to a sufficient degree? In this case, artificial light can assume the role of daylight and dynamically simulate the course of the day. Contemporary artificial lighting must be able to promote well-being and human performance. The aim of modern lighting must be to integrate the positive aspects of daylight into lighting design. Of particular importance are the changes in brightness and light color (tunable white). With the ubisys app and Zigbee lights with daylight control, you have the ability to use various pre-made HCL profiles to dynamically adjust your daytime lighting. For example, your daylight could look like this:

- Morning: warm light, less bright
- Noon: cold light, very bright
- Evening: warm light, less bright

This overall solution is particularly suitable for offices, industry (warehouses), shops (retail) and education. But it is also suitable for the private sector.

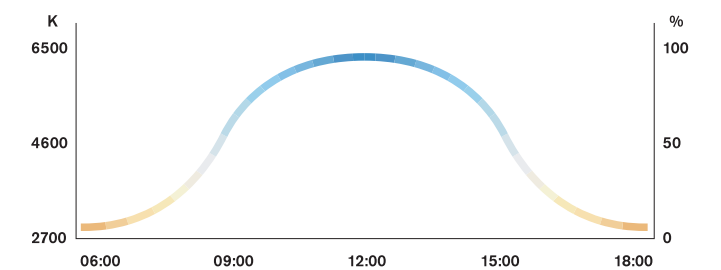



# Mini-App Store Sophisticated Automation easily Configured.

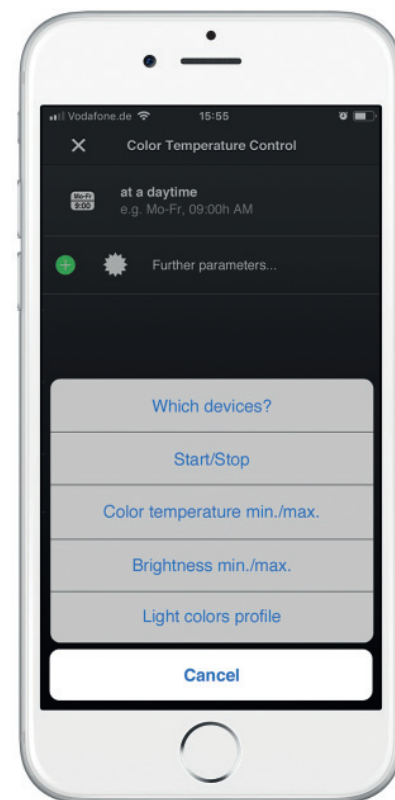

In addition to scenes and timer functions the system from ubisys also includes mini-apps adding yet another automation option. The user can extend his smart home app to further automate his system with applications found in the mini-app store. These are e.g., applications for the areas of lighting control, color temperature control, shutter control or irrigation control. Predefined parameters (e.g. start/stop times, color temperature, brightness, etc.) can be set individually in the ubisys app and combined with each other. In the background, the JavaScript engine executes the mini-apps.

*The photos show examples of screens from the mini-app „color temperature control“. Left: Description of the app in the mini-app store. Right: Defining the parameters for the automation of luminaires.*



# JavaScript Engine Individual and Customized Automation for Professionals.

ubisys

Home | Support | Contact | Language

Status Settings Network Settings Security Updates Service

Home / Scripts

## Scripts

**Scripts**  
The ubisys® Smart Home JavaScript Runtime provides a way to extend your ubisys® Smart Home system with custom logic through user-defined scripts, written in the popular JavaScript language.

**Scripts**

Test (active) Deactivate Edit Remove

**Test:**

```
1 ////////////////////////////////////////////////////////////////////
2 // lighting-occupancy-illumiance.js
3 //
4 // Copyright (c) 2018-2019 ubisys technologies GmbH. All rights reserved.
5 //
6 // Provides a script to monitor one or more occupancy and illuminance
7 // sensors and aggregate their states for automated control of
8 // a set of dimmable lights (i.e. devices with On/Off or LevelControl
9 // server cluster)
10
11 ////////////////////////////////////////////////////////////////////
12 // Configuration
13 //
14 // Zone types
15 // - Primary zone ("primary"): Dimmable lighting devices in this zone
16 //   serve as main light source and provide primary illumination.
17 // - Secondary zone ("secondary"): Dimmable lighting devices in this zone
18 //   basically provide only background illumination. Thereupon, illumination
19 //   effect in this zone is generally weaker than that in a primary zone.
20
21 // Dimming modes, relevant for dimmable lighting device only
22 // - On ("on"): Light output level in normal operating state
23 // - Standby ("standby"): Light output level in standby state, prior to succe
24 // - Off ("off"): No light output
25
26 var config = {
27 // Occupancy sensors (with occupancy sensing server cluster),
28
29
```

Save Cancel

**Logs**

Test

```
[Bitmap8:00000001]
2019-11-27 09:14:46 +0100 I print      kitchen light turned on: Success
2019-11-27 09:14:56 +0100 I print      motion sensor value changed to
[Bitmap8:00000000]
2019-11-27 09:14:56 +0100 I print      kitchen light turned off:
Success
2019-11-27 09:18:57 +0100 I print      motion sensor value changed to
[Bitmap8:00000001]
2019-11-27 09:18:57 +0100 I print      kitchen light turned on: Success
2019-11-27 09:19:07 +0100 I print      motion sensor value changed to
[Bitmap8:00000000]
2019-11-27 09:19:07 +0100 I print      kitchen light turned off:
Success
2019-11-27 09:22:01 +0100 I print      motion sensor value changed to
[Bitmap8:00000001]
2019-11-27 09:22:01 +0100 I print      kitchen light turned on: Success
2019-11-27 09:22:10 +0100 I print      motion sensor value changed to
[Bitmap8:00000000]
2019-11-27 09:22:11 +0100 I print      kitchen light turned off:
Success
2019-11-27 11:00:13 +0100 I print      motion sensor value changed to
```



If the possibilities of the mini-apps are not sufficient for the automation of your smart building system, you have another option via JavaScript:

The ubisys Smart Home JavaScript Runtime provides a way to extend your ubisys Smart Home system with custom logic through user-defined scripts, written in the popular JavaScript language. There are almost no restrictions to automate your facility according to your wishes.

For example, you can integrate a logic controlled by motion or brightness sensors into your lighting, as well as highly complex sequences with timers, web hooks and much more. Possibilities that go far beyond simple rule-based systems.

The input field for scripts is located on the web interface of your gateway. You can define as many scripts as you want and activate/deactivate them individually and manage them accordingly. An activated script is executed until it is deactivated or stopped by an error.

**System overview  
with some  
solutions/products**

**U** = ubisys products  
(more under „Products“)

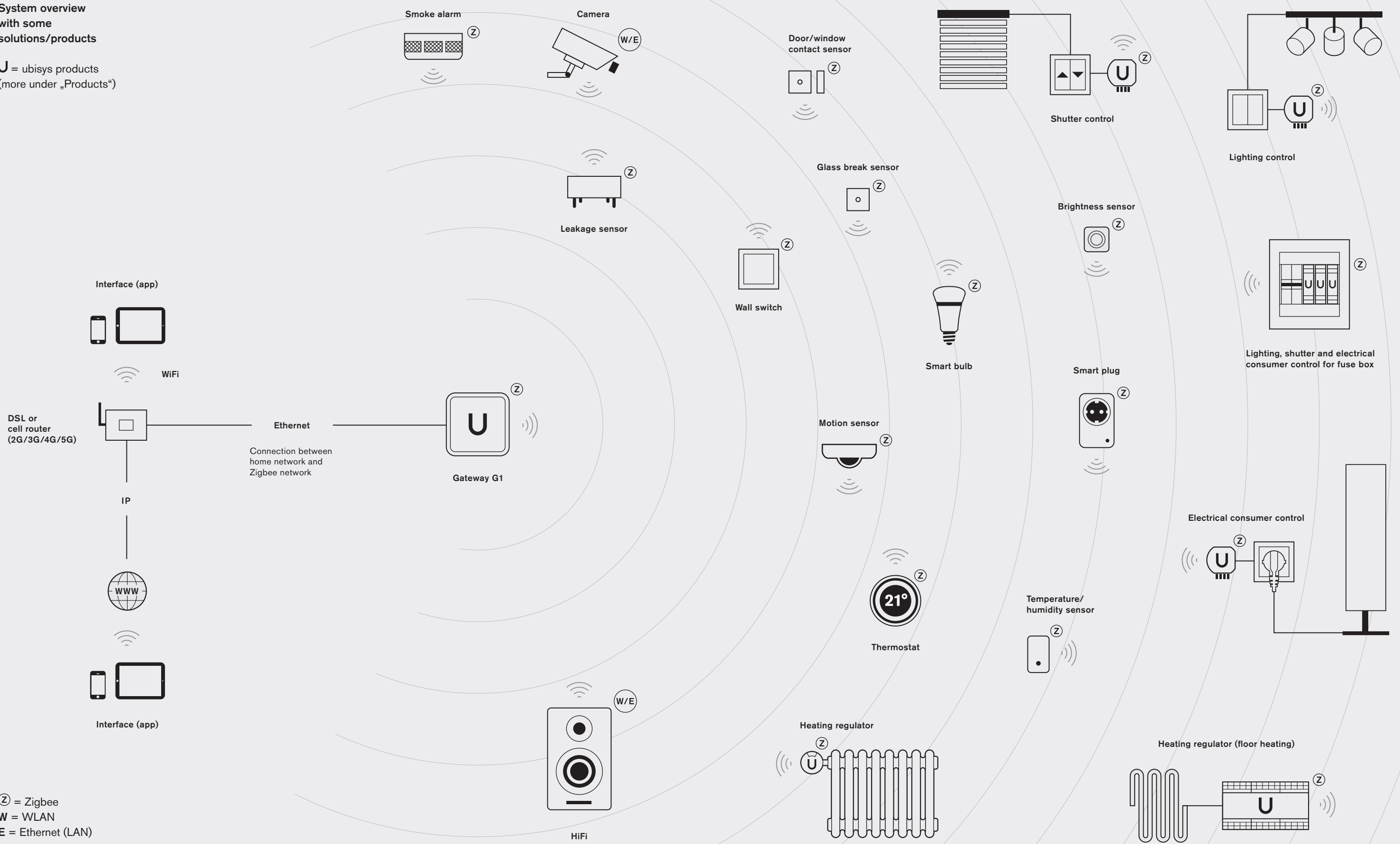

Ⓩ = Zigbee  
W = WLAN  
E = Ethernet (LAN)



### **Everything from a single Source**

ubisys Smart Home offers you the right products for every building services engineering sector:

From operating applications and lighting control to climate regulation and safety features.

We are continuously expanding our product range. Visit our website or our online shop regularly to find out about innovations from ubisys.

If you have any questions about specific products, our support team will be happy to assist you.

## Smart Home App

### Smart Home app for smartphones and tablets

The ubisys Smart Home App allows you to manage your property with an iPhone, iPad oder iPod touch – while on the road or from any room in your house. Of course there is also a version for smartphones oder tablets running on the Google Android operating system available. Operation is simple and intuitive.

You can keep an eye on the building technology any time with mobile radio or WiFi.

### Availability and Price

<b>Apple*) (iOS 6.0 or higher)</b>	<b>iPhone</b> (3GS, 4, 4S, 5, 5C, 5S, 6, 6+, 7, 8, X, 11) <b>iPad</b> (1, 2, 3, mini, Air, Air2, Pro) <b>iPod touch</b>
<b>Google Android (version 2.3 or higher)</b>	e.g. Samsung, LG, HTC, Motorola, Sony etc.
<b>Item No.</b>	1083
<b>Price</b>	<b>Free</b>



\*) **Note:** New versions of the app may require newer iOS versions. Older devices will continue to work, but new features or bug fixes will not be available.

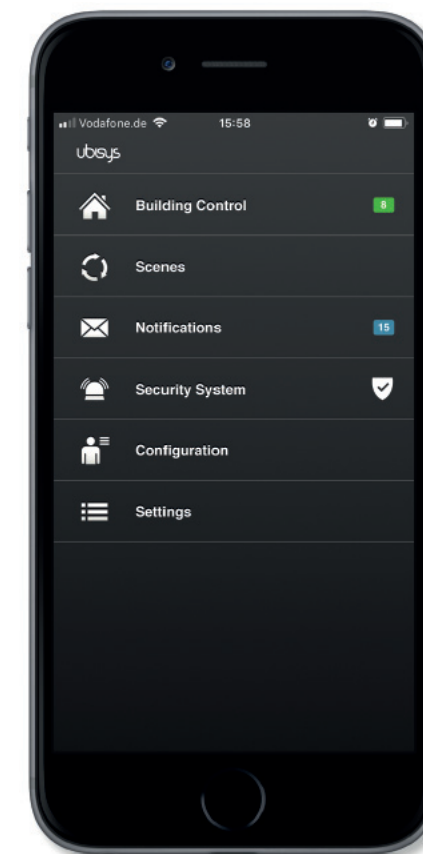

Some features at a glance:

## Building control and power consumption measurement

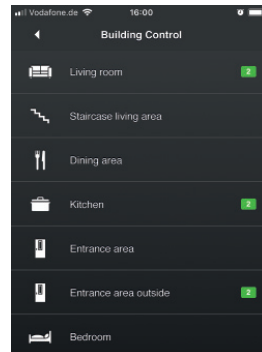

The menu item „Building control“ allows you have all rooms at a glance. The number of active components in the respective room is highlighted in green.

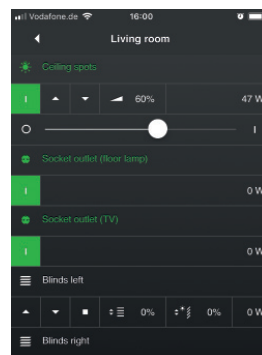

Adjust the brightness of your luminaires using sliders or up/down keys, or switch on your power sockets.

The current power consumption is also displayed simultaneously.

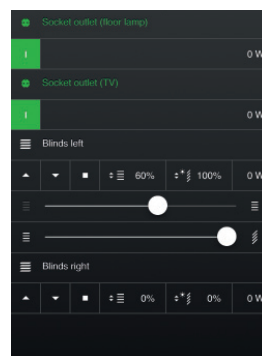

Adjust the height of your blinds and adjust the slats for optimum light incidence.

## Scenes

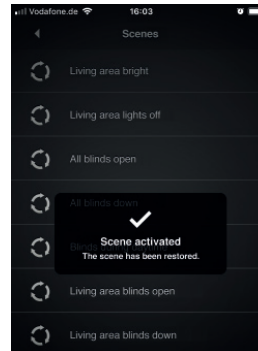

Using scenes, preconfigured settings of components can be activated with a „click“. Example: All blinds are lowered and at the same time the light is dimmed up to 50%.

## Scheduled actions

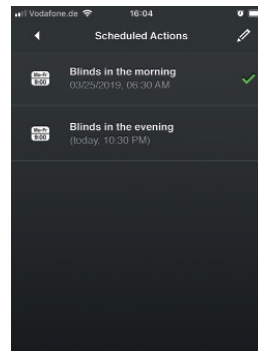

Via the menu item „Scheduled actions“ you can define time-controlled events. Simply tap to activate/deactivate the action (green checkmark).

## Configuration

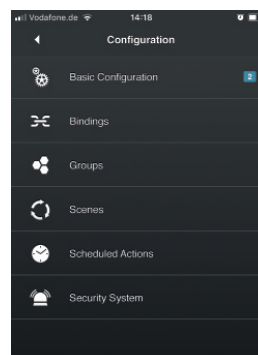

Not only is the control of your home technology simple and intuitive – the configuration of your Smart Home system also is uncomplicated.

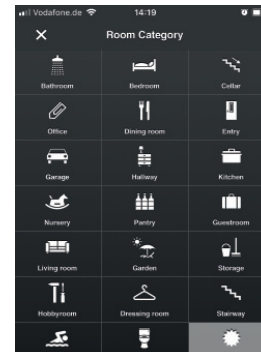

Create new rooms, name them and assign a corresponding symbol.

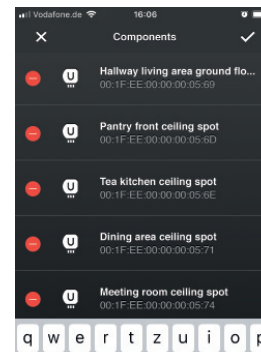

Easily add new components to your system and name them or link existing control elements to any consumer, e.g. a wall switch linked to a group of luminaires.

## Facilities

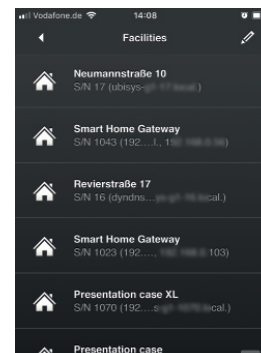

Control and monitor several properties with one app: you can change to any of the available Smart Home systems via „Settings“.

# Gateway G1

## Zigbee/Ethernet Gateway

The gateway links your wirelessly connected devices to the outside world. It establishes a connection via the internet between the ubisys Smart Home app on your mobile device and the ubisys Smart Home components installed in your home. Connect the gateway to your DSL or cell router (2G/3G/4G/5G) and manage and monitor your facility while on the road. Because the gateway is constantly running, we have designed it extremely frugally in terms of energy consumption: less than 1W is sufficient for its operation.

The wireless components of the ubisys Smart Home System are based on the international standards IEEE 802.15.4 and Zigbee. This guarantees long-term availability of components and protection of your investment. The gateway either creates a new Zigbee network as a Zigbee Coordinator and Trust Center or joins an existing network as a router.

We have attached great importance to security – no matter whether it is the transmission by Zigbee inside the object or the access from outside: Proven encryption, key exchange, and signature procedures (AES-128, ECDH, ECDSA) ensure that you always retain control. Via the web interface, you grant apps on selected end devices access to your Smart Home. Lost devices can also be permanently locked with a click of the mouse.

The intuitive user interface makes it very easy to set up the gateway. All you need is a web browser. The gateway can download updated firmware for itself and all other ubisys compo-

nents in the house. In addition, we regularly make new features available to you. And if, contrary to expectations, a problem should arise, it can also be solved. A remote maintenance function is also integrated, which only you can activate, so that our customer service has access to the device so that service cases can be processed more quickly.

Gateways that operate as „Power-over-Ethernet Powered Devices“ (PoE PD) offer an elegant installation option. Such gateways can receive their power supply via the same cable as they transmit data. Then you don't need an open socket near the gateway, nor do you need to lay a second line. If you do not yet have a PoE switch, you can use a PoE injector to feed the supply voltage.

**Privacy guaranteed: no cloud service – your data stays on the gateway**

## Technical Data

### System Details

- 32Bit ARM CPU, 400MHz
- 128MB DDR2 SDRAM
- 256MB NAND-Flash

### Power Supply

- 5V=, 48V (PoE)
- Power consumption: 0.8W

### Gateway Server Software

- Smart facility server
- Zigbee over-the-air upgrade server
- Zigbee time server
- Zigbee/IP gateway (GRIP)

- Linux operating system
- Apple HomeKit bridge
- Amazon Alexa integration
- HTTP REST API
- Data collection and storage service
- Self-contained web dashboard

### Standards

- IEEE 802.3af PD
- IEEE 802.15.4
- Zigbee 3.0

### Compatibility

- Zigbee 3.0
- Zigbee Light Link 1.0, 1.1
- Zigbee Home Automation 1.0, 1.1, 1.2
- Strong Support for Zigbee Green Power
- Diverse application domains beyond Lighting, e.g. HVAC, Security & Safety, Energy Management, Closures, etc.
- Open platform, no white listing
- Compliant devices in supported application areas expected to work out of the box, regardless of make & model

### Colour

Black (RAL 9005), Aluminium

### Material

Aluminium (brushed) and plastic

### Connections

- 10/100 Base-T Ethernet, PoE PD
- Power supply, 5V/1A (only needed if PoE is not desired)
- USB 2.0 High-Speed Host Port (for future development)
- Version with RP-SMA for external antenna available

## Scope of Delivery & Assembly

### Scope of Delivery

- IEEE 802.15.4/Zigbee Ethernet Gateway
- Plug-in power supply 5V, 1A
- Network cable, CAT6, 2m, black
- Antenna, omnidirectional, black (only for devices with external antenna)

### Assembly

- Desktop (without assembly)
- Wall assembly

You can also order the gateway for operation with an external antenna, for example if it is to be mounted in a switch cabinet made of sheet steel and the antenna must therefore be routed outwards.

**We recommend the version with integrated antenna and PoE option.**

Item No. and Price	
<b>Version</b>	
PoE*)	no
Antenna	integrated
<b>Item No.</b>	1007
<b>Price**)</b>	<b>329.00 €</b>

<b>Version</b>	
PoE*)	no
Antenna	external
<b>Item No.</b>	1021
<b>Price**)</b>	<b>339.00 €</b>
<b>Version</b>	
PoE*)	yes
Antenna	integrated
<b>Item No.</b>	1014
<b>Price**)</b>	<b>349.00 €</b>
<b>Version</b>	
PoE*)	yes
Antenna	external
<b>Item No.</b>	1038
<b>Price**)</b>	<b>359.00 €</b>

\*) Devices with PoE option can be powered either via PoE or via the supplied plug-in power supply; devices without PoE option can only be powered via the plug-in power supply.

\*\*\*) All prices incl. 19% VAT., plus postage and packing

## Web Interface

Set up your gateway easily and conveniently via the web interface.

### Features

- Network configuration (DHCP, static etc.)
- Firmware-Updates – also for already deployed devices
- Enrolling of mobile devices, and revoking access permissions
- Enable remote maintenance access

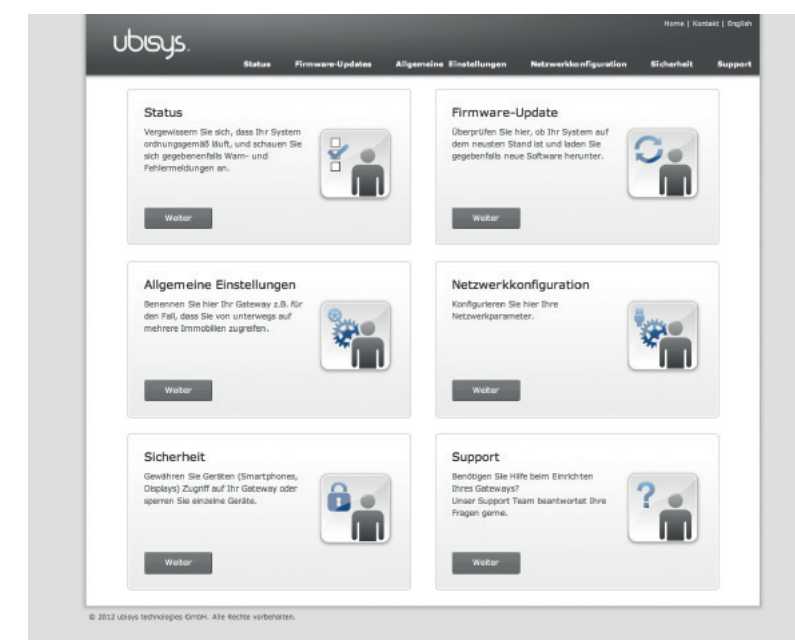
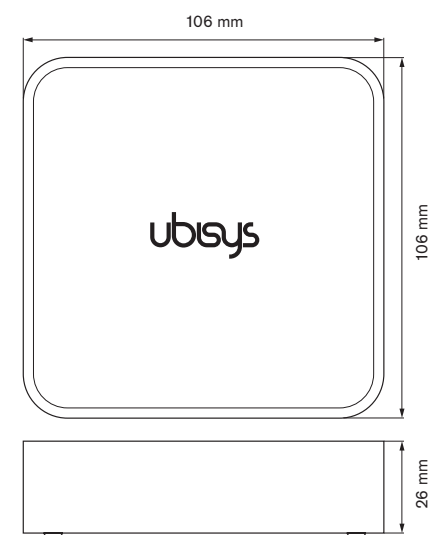
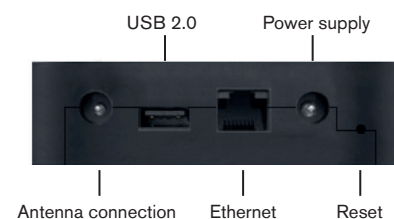

## Universal Dimmer D1

### Universal dimmer D1 – Radio networked and with power consumption metering

This universal dimmer allows for variable dimming of conventional light bulbs, high-voltage halogen lamps, low-voltage halogen lamps with a conventional wound transformer, low-voltage halogen lamps with a dimmable electronic transformer, and even dimmable LEDs and CFL lamps. Unfortunately, conventional fluorescent lights can not be dimmed. All essential electric properties (R/L/C) of the attached end devices are gauged when switched on and then the best suited dimming mode (forward or reverse phase control, also known as leading and trailing edge, respectively) will be selected automatically. Wireless, battery-free and therefore maintenance-free Zigbee Green Power switches can be linked directly.

**Integrated power consumption metering:** With this component from the ubisys Smart Home range, you get integrated power consumption metering. It allows for the actual electrical energy requirement of the connected consumer to be recorded. This lets you track exactly when and how much energy specific consumers in the house have consumed.

This component has a connection for consumers (output, load) and two connections for control elements (inputs for switches or push-buttons). The connected buttons can also be set up to be used, for example to control groups of lights or activate scenarios.

**Invisible:** The D1 can be flush-mounted behind every light switch, wall or ceiling outlet – Thus ensuring that you don't have to replace your existing switches and sockets.

If you feel inclined to install new switches for aesthetic reasons, you are free to choose the manufacturer and the appropriate program. Merely unconventional switches, e.g. those used in bus systems (KNX/EIB) are unsuitable. The particularly compact design simplifies installation.

All wireless components of the smart home system from ubisys are based on the international standards IEEE 802.15.4 and Zigbee. This guarantees long-term availability of components and protection of your investment.

Due to the robust and innovative radio technology, there are no special requirements for the electrical installation. This solution is therefore not only suitable for new buildings but also for restructurings and renovations. Bit by bit additional components can be added and integrated into your smart home. You decide yourself when and to what extent you want expand your system.

And with the Over-the-Air (OTA) firmware upgrade, this component – like all our Smart Home components – always stays up to date.

### Technical Data

#### Features

- 1 dimming end device
- 2 operating elements (push-buttons)
- Consumption metering
- Zigbee router
- Zigbee Green Power Sink

#### Output (consumer)

- 230V~, 50Hz, 500VA
- Leading phase angle (L)
- Trailing phase angle (R/C)

### Cross and multiway switching circuits:

You can also use the universal dimmer D1 in cross and multiway switching circuits. If you have any questions about optimal wiring, please contact our support.

### Standards

- IEEE 802.15.4
- Zigbee 3.0

### Colour

Black (RAL 9005)

### Material

Plastic

### Assembly & Scope of Delivery

#### Assembly

Flush-mounted assembly. Installation behind a conventional light switch, or in a wall or ceiling outlet (see „Installation“ section).

#### Scope of Delivery

- Universal dimmer D1
- Clamps (4x2, 1x3)
- Manual

Item No. and Price	
Item No.	1045
Price*)	119.00 €

\*) Price incl. 19% VAT, plus postage and packing

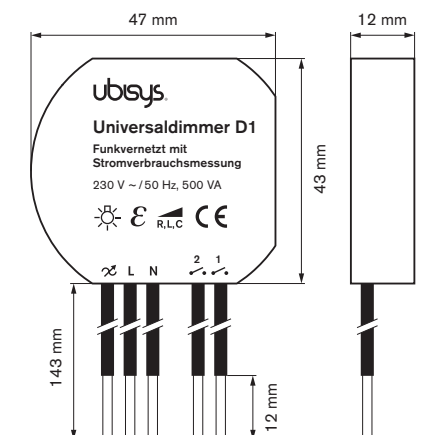



# Universal Dimmer D1-R

## Universal dimmer D1-R – Radio networked and with power consumption metering

This universal dimmer allows for variable dimming of conventional light bulbs, high-voltage halogen lamps, low-voltage halogen lamps with a conventional wound transformer, low-voltage halogen lamps with a dimmable electronic transformer, and even dimmable LEDs and CFL lamps. Unfortunately, conventional fluorescent lights can not be dimmed. All essential electric properties (R/L/C) of the attached end devices are gauged when switched on and then the best suited dimming mode (forward or reverse phase control, also known as leading and trailing edge, respectively) will be selected automatically. Wireless, battery-free and therefore maintenance-free Zigbee Green Power switches can be linked directly.

**Integrated power consumption metering:** With this component from the ubisys Smart Home range, you get integrated power consumption metering. It allows for the actual electrical energy requirement of the connected consumer to be recorded. This lets you track exactly when and how much energy specific consumers in the house have consumed.

This component has a connection for consumers (output, load) and two connections for control elements (inputs for switches or push-buttons). The connected buttons can also be set up to be used, for example to control groups of lights or activate scenarios.

**Invisible:** The universal dimmer D1-R is installed in the control cabinet of the sub-distribution on a top hat rail (DIN). The standardized design allows the replacement of an existing DIN rail device (e.g. impulse relay) by the smart universal dimmer D1-R. A flush-mounted version for installation behind a light switch, in a wall or ceiling outlet is also available. You can also use the universal dimmer D1-R in cross and multiway switching circuits.

All wireless components of the smart home system from ubisys are based on the international standards IEEE 802.15.4 and Zigbee. This guarantees long-term availability of components and protection of your investment.

Due to the robust and innovative radio technology, there are no special requirements for the electrical installation. This solution is therefore not only suitable for new buildings but also for restructurings and renovations. Bit by bit additional components can be added and integrated into your smart home. You decide yourself when and to what extent you want expand your system.

And with the Over-the-Air (OTA) firmware upgrade, this component – like all our Smart Home components – always stays up to date.

### Technical Data

#### Features

- 1 dimming end device
- 2 operating elements (push-buttons)

- Consumption metering
- Zigbee router
- Zigbee Green Power Sink

#### Output (consumer)

- 230V~, 50Hz, 500VA
- Leading phase angle (L)
- Trailing phase angle (R/C)

#### Standards

- IEEE 802.15.4
- Zigbee 3.0

#### Colour

Black (RAL 9005)

#### Material

Plastic

### Assembly & Scope of Delivery

#### Assembly

Installation on DIN-rail in the sub-distribution.

#### Scope of Delivery

- Universal dimmer D1-R
- Manual

Item No. and Price	
Item No.	1137
Price*)	139.00 €

\*) Price incl. 19% VAT, plus postage and packing

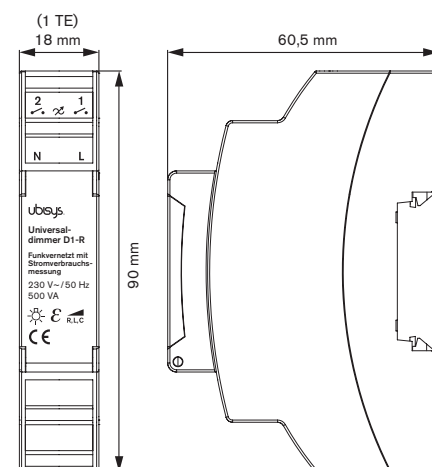

# Power Switch S1

## Universal power switch S1 – Radio networked and with power consumption metering

This universal switching actuator allows you to switch any electrical consumer/end device with a constant power draw of up 3,680VA – corresponding to a current of 16A at 230V. The actual switching is done by a bi-stable relay that only draws power when switched and also happens to be extraordinarily reliable and durable. It retains its switching state over reboots, as e.g. occur after a firmware update. Wireless, battery-free and therefore maintenance-free Zigbee Green Power switches can be linked directly.

**Integrated power consumption metering:** With this component from the ubisys Smart Home range, you get integrated power consumption metering. It allows for the actual electrical energy requirement of the connected consumer to be recorded. This lets you track exactly when and how much energy specific consumers in the house have consumed.

This component has a connection for consumers (output, load) and a connection for control elements (inputs for switches or push-buttons). The connected buttons can also be set up to be used, for example to control groups of lights or activate scenarios.

**Invisible:** The S1 can be flush-mounted behind every light switch, wall or ceiling outlet – Thus ensuring that you don't have to replace your existing switches and sockets. If you feel inclined to install new switches for aesthetic reasons, you are free to choose the

manufacturer and the appropriate program. Merely unconventional switches, e.g. those used in bus systems (KNX/EIB) are unsuitable. The particularly compact design simplifies installation.

All wireless components of the smart home system from ubisys are based on the international standards IEEE 802.15.4 and Zigbee. This guarantees long-term availability of components and protection of your investment.

Due to the robust and innovative radio technology, there are no special requirements for the electrical installation. This solution is therefore not only suitable for new buildings but also for restructurings and renovations. Bit by bit additional components can be added and integrated into your smart home. You decide yourself when and to what extent you want expand your system.

And with the Over-the-Air (OTA) firmware upgrade, this component – like all our Smart Home components – always stays up to date.

### Technical Data

#### Features

- 1 end device switch
- 1 operating element (push-button)
- Consumption metering
- Zigbee router
- Zigbee Green Power Sink

#### Output (consumer)

- 230V~, 50Hz, 3,680VA, 16A max.
- Relays, bistable

### Cross and multiway switching circuits:

You can also use the power switch S1 in cross and multiway switching circuits. If you have any questions about optimal wiring, please contact our support.

### Standards

- IEEE 802.15.4
- Zigbee 3.0

### Colour

Black (RAL 9005)

### Material

Plastic

### Assembly & Scope of Delivery

#### Assembly

Flush-mounted assembly. Installation behind a socket, conventional light switch, or in a wall or ceiling outlet (see „Installation“ section).

#### Scope of Delivery

- Power switch S1
- Clamps (4x2, 1x3)
- Manual

Item No. and Price	
Item No.	1052
Price*)	99.00 €

\*) Price incl. 19% VAT, plus postage and packing

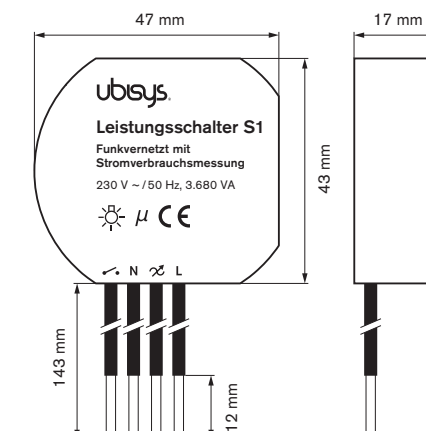

# Power Switch S1-R

## Universal power switch S1-R – Radio networked and with power consumption metering

This universal switching actuator allows you to switch any electrical consumer/end device with a constant power draw of up to 3,680VA – corresponding to a current of 16A at 230V. The actual switching is done by a bi-stable relay that only draws power when switched and also happens to be extraordinarily reliable and durable. It retains its switching state over reboots, as e.g. occur after a firmware update. Wireless, battery-free and therefore maintenance-free Zigbee Green Power switches can be linked directly.

### Integrated power consumption metering:

With this component from the ubisys Smart Home range, you get integrated power consumption metering. It allows for the actual electrical energy requirement of the connected consumer to be recorded. This lets you track exactly when and how much energy specific consumers in the house have consumed.

This component has a connection for consumers (output, load) and a connections for control elements (inputs for switches or push-buttons). The connected buttons can also be set up to be used, for example to control groups of lights or activate scenarios.

**Invisible:** The power switch S1-R is installed in the control cabinet of the sub-distribution on a top hat rail (DIN). The standardized de-

sign allows the replacement of an existing DIN rail device (e.g. impulse relay) by the smart power switch S1-R. A flush-mounted version for installation behind a light switch, in a wall or ceiling outlet is also available. You can also use the power switch S1-R in cross and multiway switching circuits.

All wireless components of the smart home system from ubisys are based on the international standards IEEE 802.15.4 and Zigbee. This guarantees long-term availability of components and protection of your investment.

Due to the robust and innovative radio technology, there are no special requirements for the electrical installation. This solution is therefore not only suitable for new buildings but also for restructurings and renovations. Bit by bit additional components can be added and integrated into your smart home. You decide yourself when and to what extent you want expand your system.

And with the Over-the-Air (OTA) firmware upgrade, this component – like all our Smart Home components – always stays up to date.

### Technical Data

#### Features

- 1 end device switch
- 2 operating element (push-button)
- Consumption metering
- Zigbee router
- Zigbee Green Power Sink

### Output (consumer)

- 230V~, 50Hz, 3,680VA, 16A max.
- Relays, bistable

### Standards

- IEEE 802.15.4
- Zigbee 3.0

### Colour

Black (RAL 9005)

### Material

Plastic

### Assembly & Scope of Delivery

#### Assembly

Installation on DIN-rail in the sub-distribution.

#### Scope of Delivery

- Power switch S1-R
- Manual

Item No. and Price	
Item No.	1151
Price*)	119.00 €

\*) Price incl. 19% VAT, plus postage and packing

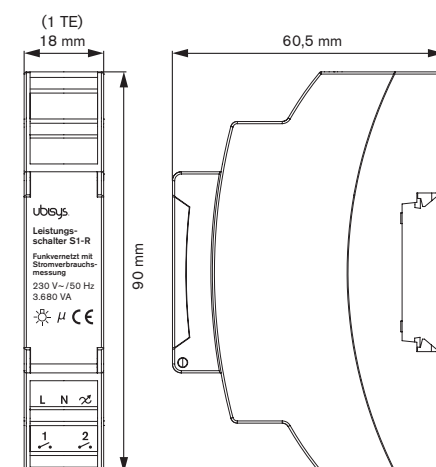

# Power Switch S2

## Power switch S2 – Radio networked and with power consumption metering

This universal switching actuator allows you to switch any two electrical consumers/end devices (motors as well) with a constant power draw of up to 500VA each. Topnotch and absolutely wear-free semiconductor switches (TRIACs) guarantee a very long life span and silent switching. Perfectly suited for double light fixtures and double switches. Wireless, battery-free and therefore maintenance-free Zigbee Green Power switches can be linked directly.

### Integrated power consumption metering:

With this component from the ubisys Smart Home range, you get integrated power consumption metering. It allows for the actual electrical energy requirement of the connected consumer to be recorded. This lets you track exactly when and how much energy specific consumers in the house have consumed.

This component has two connections for consumers (output, load) and two connections for control elements (inputs for switches or push-buttons). The connected buttons can also be set up to be used, for example to control groups of lights or activate scenarios.

**Invisible:** The S2 can be flush-mounted behind every light switch, wall or ceiling outlet – Thus ensuring that you don't have to replace your existing switches and sockets. If you feel inclined to install new switches for aesthetic reasons, you are free to choose the manufacturer and the appropriate program.

Merely unconventional switches, e.g. those used in bus systems (KNX/EIB) are unsuitable. The particularly compact design simplifies installation.

All wireless components of the smart home system from ubisys are based on the international standards IEEE 802.15.4 and Zigbee. This guarantees long-term availability of components and protection of your investment.

Due to the robust and innovative radio technology, there are no special requirements for the electrical installation. This solution is therefore not only suitable for new buildings but also for restructurings and renovations. Bit by bit additional components can be added and integrated into your smart home. You decide yourself when and to what extent you want expand your system.

And with the Over-the-Air (OTA) firmware upgrade, this component – like all our Smart Home components – always stays up to date.

### Technical Data

#### Features

- 2 end devices switch
- 2 operating elements (push-buttons)
- Consumption metering
- Zigbee router
- Zigbee Green Power Sink

#### Output (consumer)

- 1: 230V~, 50Hz, 500VA
- 2: 230V~, 50Hz, 500VA
- TRIAC

### Cross and multiway switching circuits:

You can also use the power switch S2 in cross and multiway switching circuits. If you have any questions about optimal wiring, please contact our support.

### Standards

- IEEE 802.15.4
- Zigbee 3.0

### Colour

Black (RAL 9005)

### Material

Plastic

### Assembly & Scope of Delivery

#### Assembly

Flush-mounted assembly. Installation behind a conventional light switch, or in a wall or ceiling outlet (see „Installation“ section).

#### Scope of Delivery

- Power switch S2
- Clamps (5x2, 1x3)
- Manual

Item No. and Price	
Item No.	1069
Price*)	99.00 €

\*) Price incl. 19% VAT, plus postage and packing

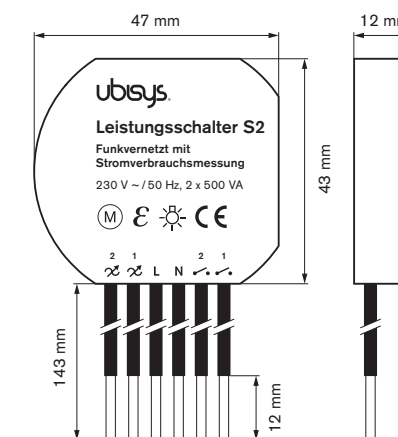

# Power Switch S2-R

## Power switch S2-R – Radio networked and with power consumption metering

This universal switching actuator allows you to switch any two electrical consumers/end devices (motors as well) with a constant power draw of up to 500VA each. Topnotch and absolutely wear-free semiconductor switches (TRIACs) guarantee a very long-life span and silent switching. Perfectly suited for double light fixtures and double switches. Wireless, battery-free and therefore maintenance-free Zigbee Green Power switches can be linked directly.

### Integrated power consumption metering:

With this component from the ubisys Smart Home range, you get integrated power consumption metering. It allows for the actual electrical energy requirement of the connected consumer to be recorded. This lets you track exactly when and how much energy specific consumers in the house have consumed.

This component has two connections for consumers (output, load) and two connections for control elements (inputs for switches or push-buttons). The connected buttons can also be set up to be used, for example to control groups of lights or activate scenarios.

**Invisible:** The power switch S2-R is installed in the control cabinet of the sub-distribution on a top hat rail (DIN). The standardized design allows the replacement of an existing DIN

rail device (e.g. impulse relay) by the smart power switch S2-R. A flush-mounted version for installation behind a light switch, in a wall or ceiling outlet is also available. You can also use the power switch S2-R in cross and multiway switching circuits.

All wireless components of the smart home system from ubisys are based on the international standards IEEE 802.15.4 and Zigbee. This guarantees long-term availability of components and protection of your investment.

Due to the robust and innovative radio technology, there are no special requirements for the electrical installation. This solution is therefore not only suitable for new buildings but also for restructurings and renovations. Bit by bit additional components can be added and integrated into your smart home. You decide yourself when and to what extent you want expand your system.

And with the Over-the-Air (OTA) firmware upgrade, this component – like all our Smart Home components – always stays up to date.

## Technical Data

### Features

- 2 end devices switch
- 2 operating elements (push-buttons)
- Consumption metering
- Zigbee router
- Zigbee Green Power Sink

### Output (consumer)

- 1: 230V~, 50Hz, 500VA
- 2: 230V~, 50Hz, 500VA
- TRIAC

### Standards

- IEEE 802.15.4
- Zigbee 3.0

### Colour

Black (RAL 9005)

### Material

Plastic

### Assembly & Scope of Delivery

#### Assembly

Installation on DIN-rail in the sub-distribution.

#### Scope of Delivery

- Power switch S2-R
- Manual

Item No. and Price	
Item No.	1168
Price*)	119.00 €

\*) Price incl. 19% VAT, plus postage and packing

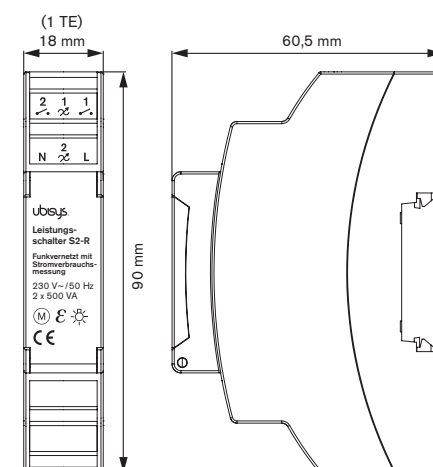

# Products / Shading



# Shutter Control J1

## Shutter control J1 – Radio networked and with power consumption metering

This shutter control allows you to drive your shutters, awnings, screens and blinds up and down. Connect conventional tubular motors with a mechanical or electronic limit switch. After the teach-in phase (calibration), the blind controller can be used to position the height and if possible the slat angle. You can use motors with a max. power output of up to 500VA. Wireless, battery-free and therefore maintenance-free Zigbee Green Power switches can be linked directly.

**Integrated power consumption metering:** With this component from the ubisys Smart Home range, you get integrated power consumption metering. It allows for the actual electrical energy requirement of the connected consumer to be recorded. This lets you track exactly when and how much energy specific consumers in the house have consumed.

This component has a connection for motors and two connections for control elements (inputs for switches or push-buttons). The connected buttons can also be set up to be used, for example to control groups of lights or activate scenarios.

**Invisible:** The J1 can be flush-mounted behind every shutter double switch, wall or ceiling outlet – Thus ensuring that you don't have to replace your existing switches and sockets. If you feel inclined to install new switches for

aesthetic reasons, you are free to choose the manufacturer and the appropriate program. Merely unconventional switches, e.g. those used in bus systems (KNX/EIB) are unsuitable. The particularly compact design simplifies installation.

All wireless components of the smart home system from ubisys are based on the international standards IEEE 802.15.4 and Zigbee. This guarantees long-term availability of components and protection of your investment.

Due to the robust and innovative radio technology, there are no special requirements for the electrical installation. This solution is therefore not only suitable for new buildings but also for restructurings and renovations. Bit by bit additional components can be added and integrated into your smart home. You decide yourself when and to what extent you want expand your system.

And with the Over-the-Air (OTA) firmware upgrade, this component – like all our Smart Home components – always stays up to date.

### Technical Data

#### Features

- 1 shutter control
- 2 operating elements (push-buttons)
- Consumption metering
- Zigbee router
- Zigbee Green Power Sink



### Output (consumer)

- 230V~, 50Hz, 500VA
- TRIAC

### Standards

- IEEE 802.15.4
- Zigbee 3.0

### Colour

Black (RAL 9005)

### Material

Plastic

### Assembly & Scope of Delivery

#### Assembly

Flush-mounted assembly. Installation behind a conventional shutter switch, or in a wall or ceiling outlet (see „Installation“ section) or shutter box.

#### Scope of Delivery

- Shutter control J1
- Clamps (4x2, 1x3)
- Manual

Item No. and Price	
Item No.	1076
Price*)	149.00 €

\*) Price incl. 19% VAT, plus postage and packing

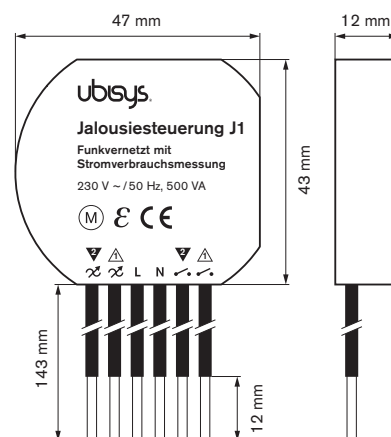

# Shutter Control J1-R

## Shutter control J1-R – Radio networked and with power consumption metering

This shutter control allows you to drive your shutters, awnings, screens and blinds up and down. Connect conventional tubular motors with mechanical or electronic limit switch. After the teach-in phase (calibration), the blind controller can be used to position the height and possibly the slat angle. You can use motors with a max. power output of up to 500VA. Wireless, battery-free and therefore maintenance-free Zigbee Green Power switches can be linked directly.

**Integrated power consumption metering:** With this component from the ubisys Smart Home range, you get integrated power consumption metering. It allows for the actual electrical energy requirement of the connected consumer to be recorded. This lets you track exactly when and how much energy specific consumers in the house have consumed.

This component has a connection for motors and two connections for control elements (inputs for switches or push-buttons). The connected buttons can also be set up to be used, for example to control groups of lights or activate scenarios.

**Invisible:** The shutter control J1-R is installed in the control cabinet of the sub-distribution on a top hat rail (DIN). The standardized design allows the replacement of an existing

DIN rail device (e.g. impulse relay) by the smart shutter control J1-R. A flush-mounted version for installation behind a light switch, in a wall or ceiling outlet is also available. You can also use the shutter control J1-R in cross and multiway switching circuits.

All wireless components of the smart home system from ubisys are based on the international standards IEEE 802.15.4 and Zigbee. This guarantees long-term availability of components and protection of your investment.

Due to the robust and innovative radio technology, there are no special requirements for the electrical installation. This solution is therefore not only suitable for new buildings but also for restructurings and renovations. Bit by bit additional components can be added and integrated into your smart home. You decide yourself when and to what extent you want expand your system.

And with the Over-the-Air (OTA) firmware upgrade, this component – like all our Smart Home components – always stays up to date.

### Technical Data

#### Features

- 1 shutter control
- 2 operating elements (push-buttons)
- Consumption metering
- Zigbee router
- Zigbee Green Power Sink

### Output (consumer)

- 230V~, 50Hz, 500VA
- TRIAC

### Standards

- IEEE 802.15.4
- Zigbee 3.0

### Colour

Black (RAL 9005)

### Material

Plastic

### Assembly & Scope of Delivery

#### Assembly

Installation on DIN-rail in the sub-distribution.

#### Scope of Delivery

- Shutter control J1-R
- Manual

Item No. and Price	
Item No.	1144
Price*)	169.00 €

\*) Price incl. 19% VAT, plus postage and packing

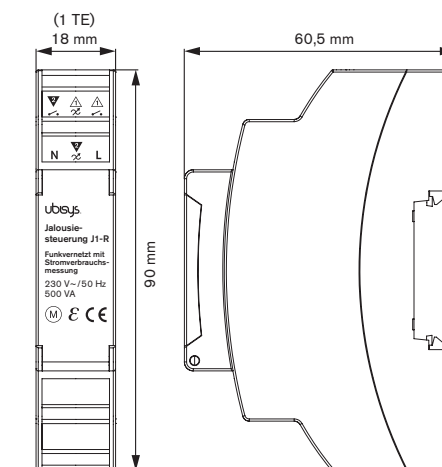

# Heating Regulator H1

## Radiator thermostat – radio networked

The heating regulator H1 is a radio controlled actuator with an integrated thermostat for radiators. It can be retrofitted at any time and therefore is also suitable for existing buildings. The H1 is battery powered and characterized by its low power consumption. In addition to controlling it via a smart home system, the desired temperature can also be set on the device via a rotary knob.

The device has internal temperature sensors, but can also be linked to a Zigbee room temperature sensor if the gateway supports this feature.

And with the over-the-air (OTA) firmware upgrade, this component, like all our smart home components, stays up to date.

## Technical Data

- Features**
- Regulating of a radiator

- Standards**
- IEEE 802.15.4
  - Zigbee 3.0

## Assembly & Scope of Delivery

**Assembly**  
Screw assembly

- Scope of Delivery**
- Heating regulator H1
  - Manual

Item No. and Price	
Item No.	1267
Price*)	79.99 €

\*) Price incl. 19% VAT, plus postage and packing

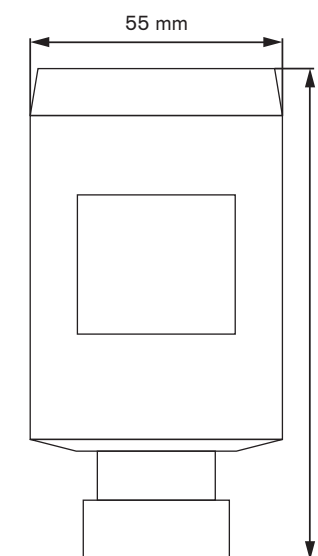

# Heating Regulator H10

## Heating regulator H10 for underfloor heating systems – wireless networked

The heating regulator H10 is a radio controlled room temperature regulator for up to 10 independent heating and/or cooling zones.

Moreover the heating regulator H10 allows for individual room control and is very versatile due to its modular concept. The base module fits up to 10 thermo-electric actuators for underfloor heating to be connected to your smart building. Optional add-on modules offer controlling of circulation pumps, the detection of forward and return flow temperatures for advanced control algorithms, generating heat requirement notifications to conventional boilers, and connecting existing room thermostats. It goes without saying that includes communicating with Zigbee thermostats and temperature sensors. Available in a 24V and 230V version.

### Some features at a glance:

- Modular design – perfectly suited for adapting to customer's heating infrastructure with following devices: Thermostat interface, heating/cooling demand module, sensor interface and pump control
- Base module H10-B for direct driving of thermoelectric radiator valves: either 10 heating or cooling zones (one valve control output per zone, two-pipe system); or 5 heating and cooling zones (two valve control outputs per zone, four-pipe system)
- Can work in conjunction with other thermostats in a leader/follower setup

- Compatible with Legrand's in-wall thermostat UI Model No. 0 663 40
- Different operating modes: Under normal operating conditions thermostat set-points, occupancy information and temperature readings are used for closed-loop control of the temperature; When sensor reports are missing the device enters back-up mode and applies default valve opening values with different pre-sets for summer and winter seasons; Automatic temperature regulation of the built-in thermostat can be overruled by setting arbitrary steering values per valve output, e.g. 10%, 50% or 100% using Zigbee level steering; Pass-through mode allows legacy wired in-wall thermostats to control valve outputs, i.e. the valve behaves like it was directly wired to the legacy thermostat; Manual mode allows valve control using a button (bypassing valve settings determined by either the Zigbee thermostat, legacy thermostats, or Zigbee level steering)
- H10/24 and H10/230 employ staggered switching of valves to spread excessive valve turn-on currents over a time
- Supports classic and Green Power sensors directly

### Technical Data

#### Further features

- Individual room control for floor heating
- Zigbee router
- Zigbee Green Power Sink

### Nominal voltage

- 24V-version: 24V
- 230V-version: 230V~, 50Hz

### Max. switching capacity

- 24V-version: 5W per output
- 230V-version: 10VA per output

### Standards

- IEEE 802.15.4
- Zigbee 3.0

### Assembly & Scope of Delivery

**Assembly**  
DIN-rail.

### Scope of Delivery

- Heating regulator H10
- Manual

### Item No. and Price

Item No.	1205 (230V)
	1199 (24V)
Price*)	249.00 €

\*) Price incl. 19% VAT, plus postage and packing

## For which heating/cooling systems is the heating regulator H10 suitable?

The heating regulator H10 has 10 independent control circuits (PI controller) for temperature control in up to 10 different zones. The zones can either be heated or cooled, or alternatively 5 zones can be heated and cooled. Room temperature sensors include wireless temperature sensors (Zigbee or Green Power), wall-mounted thermostats - with Zigbee or conventional cabling („on/off“) - and wired 1-Wire® sensors.

The device supports two- and four-pipe systems, it can optionally report heating and cooling requirements and control circulation pumps. The measurement of forward and return flow temperatures enables precise control algorithms.

Thus, the H10 and the additional options available (thermostat interface, heat and cold demand detector, sensor interface, pump control) are suitable for a wide range of heating and cooling systems.

By way of example, a 2-pipe heating/cooling system is shown here that heats or cools via the heat pump in the heat and cold generator (illustration: heating).

The control would be done via a wired room thermostat or via the ubisys Smart Home app.

Further application examples can be found on [www.ubisys.de](http://www.ubisys.de).

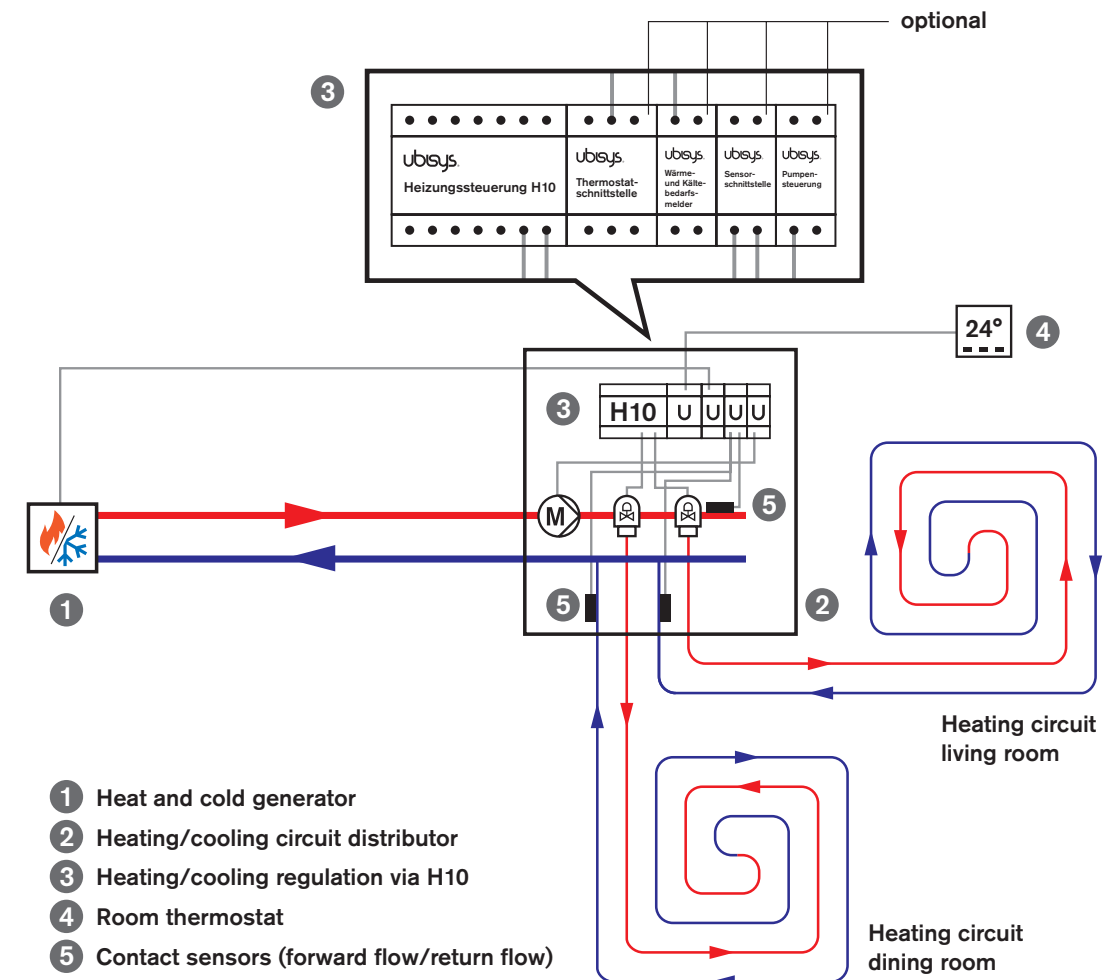
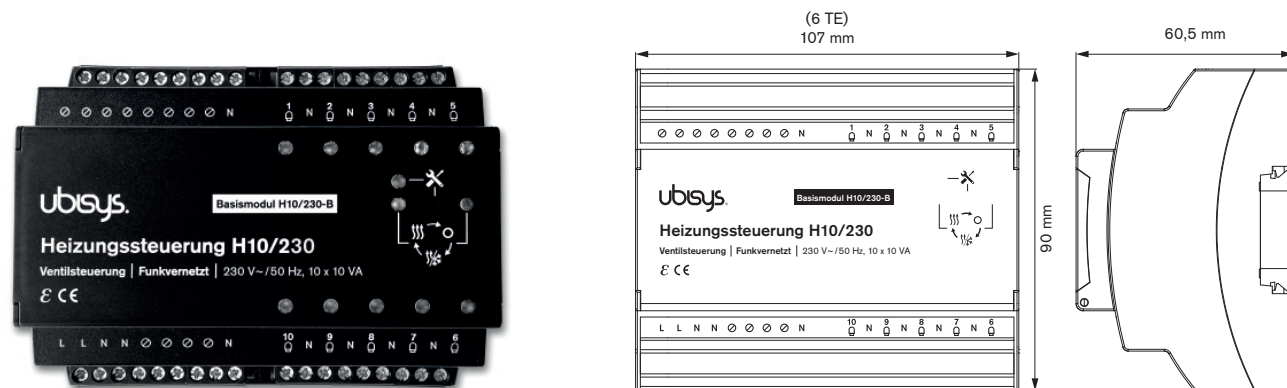

### Note:

The additional modules thermostat interface, heat and cold demand detector, sensor interface and/or pump control can be optionally added. In principle, the base module is sufficient to integrate your underfloor heating/cooling into your ubisys Smart Home.

# Thermostat Interface for H10

## Note:

The thermostat interface is an additional option. Prerequisite for commissioning is the installation of the heating control H10 for underfloor heating systems.

The thermostat interface (option H10/24-XI or H10/230-XI) is an accessory to the ubisys heating control H10. It allows the integration of conventional 24V wall thermostats into the H10 heating control and is connected to the base module H10 via an extension interface. The thermostat interface is available in a 24V and a 230V version.

## Technical Data

### Features

- Interface for built-in room thermostats

### Nominal Voltage

- 24V-version: 24V
- 230V-version: 230V~, 50Hz

### Assembly & Scope of Delivery

#### Assembly

DIN-rail. The thermostat interface is connected to the base module H10 via an extension interface.

## Scope of Delivery

- Thermostat interface (24V or 230V) for H10
- Manual

### Item No. and Price

Item No.	1205 (230V) 1212 (24V)
Price*)	119.00 €

\*) Price incl. 19% VAT, plus postage and packing

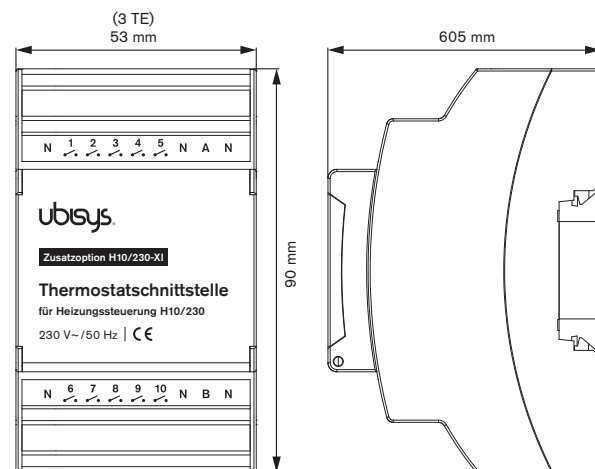

# Pump Control for H10

## Note:

The pump control is an additional option. Prerequisite for commissioning is the installation of the heating control H10 for underfloor heating systems.

The pump control (additional option H10-XP) is an additional device for the ubisys heating control H10. It enables the integration of circulation pumps in underfloor heatings and is connected to the base module H10 via an extension interface.

## Technical Data

### Features

- Regulation of circulation pumps in underfloor heating systems

### Nominal Voltage

- 230V~, 50Hz

### Max. Switching Capacity

- 500VA per output

### Assembly & Scope of Delivery

#### Assembly

DIN-rail. The pump control is connected to the base module H10 via an extension interface.

## Scope of Delivery

- Pump control for H10
- Manual

### Item No. and Price

Item No.	1250
Price*)	119.00 €

\*) Price incl. 19% VAT, plus postage and packing

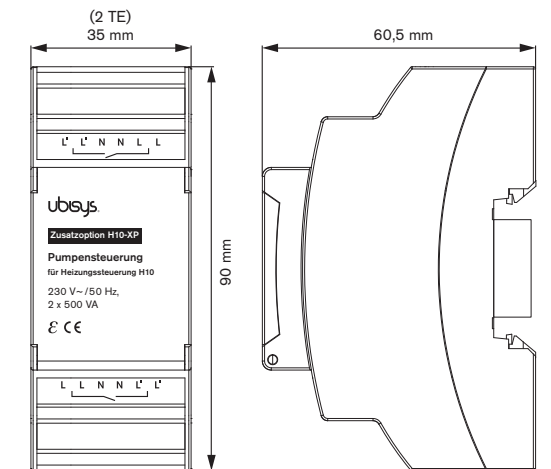



# Heating/Cooling Demand Module for H10

**Note:**

The heating and cooling demand detector is an additional option. Prerequisite for commissioning is the installation of the heating control H10 for underfloor heating systems.

The heating and cooling demand detector (additional option H10-XS) is an accessory for the ubisys heating control H10. It is used to generate heating and cooling demand messages sent to conventional boilers in underfloor heating systems and is connected to the base module H10 via an extension interface.

The messages are provided in the form of a potential-free switch, thus allowing the influencing of heat or cold generators, or switching on/off simple heat sources such as hot water boilers.

**Technical Data**

**Features**

- Generates heating and cooling demand messages sent to conventional boilers in underfloor heating systems

**Max. Switching Voltage**

- 230V~, 50Hz

**Max. Switching Capacity**

- 2 x 1,800VA

**Assembly & Scope of Delivery**

**Assembly**

DIN-rail. The heating and cooling demand detector is connected to the base module H10 via an extension interface.

**Scope of Delivery**

- Heating/Cooling Demand Module for H10
- Manual

**Item No. and Price**

Item No.	1243
Price*)	119.00 €

\*) Price incl. 19% VAT, plus postage and packing

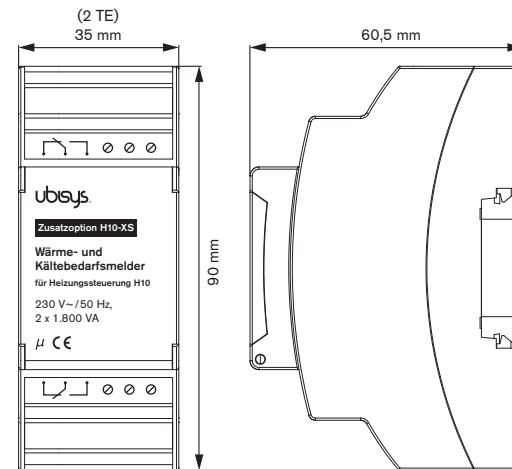
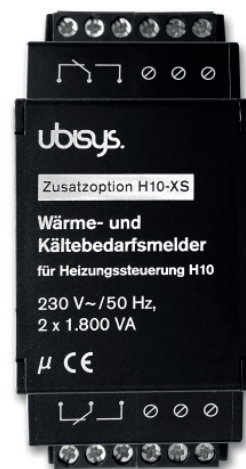

# Sensor Interface for H10

**Note:**

The sensor interface is an additional option. Prerequisite for commissioning is the installation of the heating control H10 for underfloor heating systems.

The sensor interface (option H10-XW) is an accessory to the ubisys heating control H10. It allows the integration of contact temperature sensors to determine forward and return flow temperatures and is connected to the base module H10 via an extension interface.

**Note:** Use only sensors sold by ubisys, e.g. H10-XW-F, H10-XW-R01, H10-XW-R02, ...etc., because the measurand is preconfigured. The sensors are available at [www.smarthome-store](http://www.smarthome-store). Commercially available standard sensors are not supported.

**Technical Data**

**Features**

- Interface for contact temperature sensors

**Nominal Voltage**

- 5V

**Max. Power Supply and Standby Consumption**

- 140mA@5V
- 0.05W

**Max. Amount of Sensors**

- 64

**Assembly & Scope of Delivery**

**Assembly**

DIN-rail. The sensor interface is connected to the base module H10 via an extension interface.

**Scope of Delivery**

- Sensor interface
- Manual

**Item No. and Price**

Item No.	1236
Price*)	119.00 €

\*) Price incl. 19% VAT, plus postage and packing

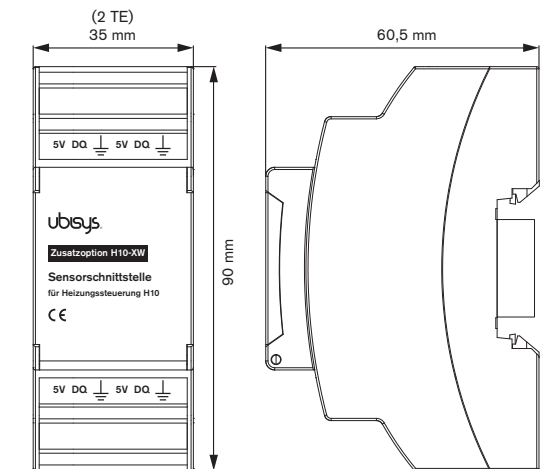

# Contact Sensor for H10

## Note:

The contact sensors are an accessory item for the H10 heating system.

The contact sensor is used to measure the forward and return flow temperature of your underfloor heating for smart heating regulation – via ubisys Smart Home App or automatically. To record the measured temperature, it is wired to the sensor interface (additional option H10-XW) for the heating regulator H10.

**Note:** Only use contact sensors distributed by ubisys., e.g. H10-XW-F, H10-XW-R01, H10-XW-R02, ...etc., since the measured variable is preconfigured. The sensors are available on [www.smarthome-store](http://www.smarthome-store). Commercially available customary sensors are not supported.

## Technical Data

### Features

- Recording of forward and return flow temperature

### Bus technology and operating voltage (logic level)

- 1-Wire
- 5V

### Type

- TO-92

### Temperature range and accuracy

- 55°C - 125°C
- +/- 0,5°

### Dimensions

- Length: 3m

### Material

- Stainless steel (sensor part)

## Assembly & Scope of Delivery

### Assembly

Wiring or fixing by means of cable ties

## Scope of Delivery

- 1 pc. contact sensors (depending on version)
- 1 pc. cable tie (stainless steel) for fixation

### Item No. and Price

Item No.	Miscellaneous
Price*)	9.99 €

## Please also consider our sets with 6 or 11 sensors:

### Item No. and Price

Item No.	1274 (set with 6 sensors)
Price*)	49.00 €
Item No.	1281 (set with 11 sensors)
Price*)	79.00 €

\*) Price incl. 19% VAT, plus postage and packing



# Control Unit C4

## Control unit C4 – Radio networked

The control unit C4 can be connected to other Zigbee components from our Smart Home product line to control lamps, shutters or other electrical consumers\*). This allows you to integrate more push-buttons, switches, motion sensors or twilight switches in your system.

**Note:** The control unit C4 is to be considered as an supplementary option, which provides additional inputs.

This component has 4 connectors for controls (inputs for switches or push-buttons). The connected push-buttons can be set up so that you can dim lights, turn on/off electrical consumers, control shutters or call up scenes, for example.

**Invisible:** The C4 control unit can be flush-mounted behind every light switch, wall or ceiling outlet – Thus ensuring that you don't have to replace your existing switches and sockets. If you feel inclined to install new switches for aesthetic reasons, you are free to choose the manufacturer and the appropriate program. Merely unconventional switches, e.g. those used in bus systems (KNX/EIB) are unsuitable. The particularly compact design simplifies installation.

All wireless components of the smart home system from ubisys are based on the international standards IEEE 802.15.4 and Zigbee. This guarantees long-term availability of components and protection of your investment.

Due to the robust and innovative radio technology, there are no special requirements for the electrical installation. This solution is therefore not only suitable for new buildings but also for restructurings and renovations. Bit by bit additional components can be added and integrated into your smart home. You decide yourself when and to what extent you want expand your system.

And with the Over-the-Air (OTA) firmware upgrade, this component – like all our Smart Home components – always stays up to date.

### Technical Data

#### Features

- 4 inputs (push-buttons)
- Zigbee router

#### Standards

- IEEE 802.15.4
- Zigbee 3.0

### Colour

Black (RAL 9005)

### Material

Plastic

### Assembly & Scope of Delivery

#### Assembly

Flush-mounted assembly. Installation behind a conventional light switch, or in a wall or ceiling outlet (see „Installation“ section).

#### Scope of Delivery

- Control unit C4
- Clamps (5x2, 1x3)
- Manual

Item No. and Price	
Item No.	1120
Price**)	99.00 €

\*) There may be restrictions on the features that can be used simultaneously

\*\*\*) Price incl. 19% VAT, plus postage and packing

# Router R0

## Router R0 – Radio networked

The router R0 is a Zigbee radio router and is used for routing Zigbee data in widely ramified buildings.

**Note:** The Router R0 is to be considered as an additional option. The components D1/-R, S1/-R, S2/-R, J1/-R, C4 and G1 already feature the router function. The router R0 has no connectors for control units (switch inputs, push-buttons or loads). Using this device makes only sense when combined with other Zigbee devices, mainly as a range extender.

**Invisible:** The Router R0 can be flush-mounted behind every light switch, wall or ceiling outlet. The particularly compact design simplifies installation.

All wireless components of the smart home system from ubisys are based on the international standards IEEE 802.15.4 and Zigbee. This guarantees long-term availability of components and protection of your investment.

Due to the robust and innovative radio technology, there are no special requirements for the electrical installation. This solution is therefore not only suitable for new buildings but also for restructurings and renovations. Bit by bit additional components can be added and integrated into your smart home. You decide yourself when and to what extent you want expand your system.

And with the Over-the-Air (OTA) firmware upgrade, this component – like all our Smart Home components – always stays up to date.

### Technical Data

#### Features

- Zigbee router

#### Standards

- IEEE 802.15.4
- Zigbee 3.0

### Colour

Black (RAL 9005)

### Material

Plastic

### Assembly & Scope of Delivery

#### Assembly

Flush-mounted assembly. Installation behind a conventional light switch, or in a wall or ceiling outlet (see „Installation“ section)..

#### Scope of Delivery

- Router R0
- Clamps
- Manual

Item No. and Price	
Item No.	1182
Price*)	79.00 €

\*) Price incl. 19% VAT, plus postage and packing

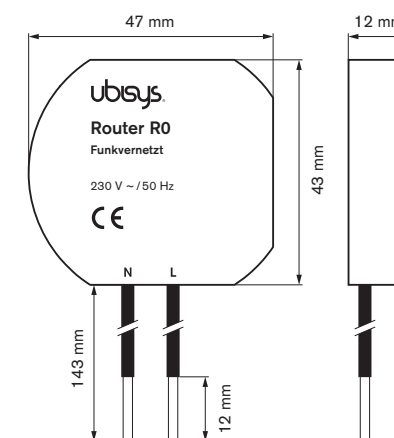
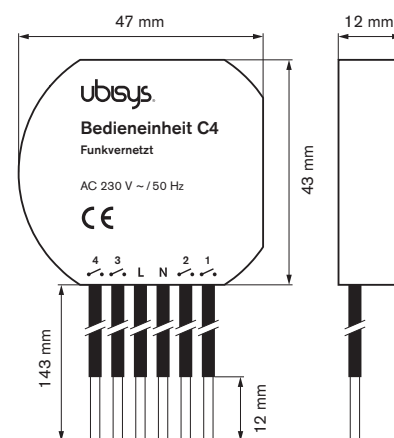

## Compatible Zigbee Products of other Manufacturers

### **Third-party Products**

The ubisys Smart Home platform is open for products from other manufacturers also supporting the Zigbee standard. These include smoke alarms, door/window contacts and various coloured or white light sources with adjustable colour temperature, including those with conventional

sockets such as E27 or GU-10, LED strips or fairy lights.

We check the compatibility of the products and cooperate closely with third party manufacturers to ensure a smooth interaction of the components. Not all products support all features equally. Here you can find out, which products you can use in your ubisys system and what restrictions you may have to expect.





# Example Zigbee Smart Bulbs



Smart bulbs with E27- (left) and GU-10 socket (right).

## Zigbee Smart Bulbs in your ubisys Smart Home network

The large manufacturers of lamps and illuminants have models with already factory-installed Zigbee connection or have announced corresponding devices, e.g. OSRAM, Philips, General Electric and Samsung. You can operate these lamps in your ubisys Smart Home Zigbee network. They can be switched on and off, dimmed, adjusted in color, integrated into groups and scenes or linked to a wall switch.

If you link a wall switch to the lamp using a dimmer or the C4 control unit from ubisys, you can use the switch to dim, switch or call up a scene ("lighting mood"). If you switch off the lamp it will continue to function as a Zigbee router in your network and thus contribute to optimal radio coverage – even if it is not lit. The lamp can also be switched on again using the app or time control.

## Compatibility matrix

We have tested some models in combination with our gateway G1 and our smart home apps for iOS and Android. It is possible that newer firmware versions with extended functionality have been released in the meantime (Date: May 2017):

	Groups	Scenes	Reporting	Updates
OSRAM LIGHTIFY Classic A60 RGBW	✓	✓	✓	✓
OSRAM LIGHTIFY Classic A60 tunable white	?	?	?	✓
OSRAM LIGHTIFY PAR16 50 tunable white	✓	✓	✓	✓
OSRAM LIGHTIFY Downlight tunable white	?	?	?	✓
OSRAM LIGHTIFY Flex RGBW	?	?	?	✓
OSRAM LIGHTIFY Surface light tunable white	?	?	?	✓
OSRAM LIGHTIFY Circle	?	?	?	✓
OSRAM LIGHTIFY Gardenspot Mini white	?	?	?	✓
Philips hue Connected Bulb A19 (E27)	✓	✓	⊘	✓
Philips hue lux (E27)	✓	✓	⊘	✓
Philips hue 7W BR30 Connected Downlight	✓	✓	⊘	✓
Philips hue GU-10	✓	✓	⊘	✓
Philips Friends of hue LivingColors Bloom	?	?	?	✓
Philips Friends of hue LivingColors Iris	?	?	?	✓
Philips Friends of hue LightStrips	✓	✓	⊘	✓

✓ supported    ✓ yes, but only via own bridge    ⊘ not supported    ? to be verified

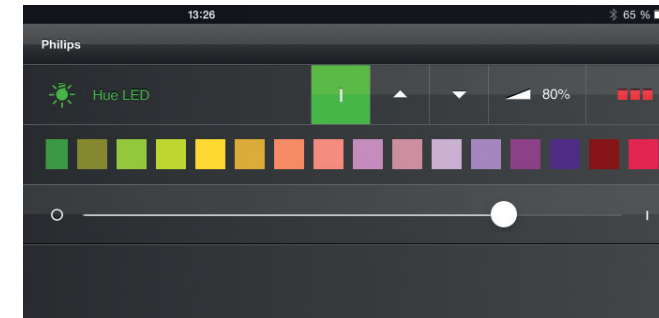

Switch, dim and set the colour with the ubisys Smart Home app.

## What are the restrictions?

Some lamps (e.g. Philips hue) do not support automatic reports, the so called „Zigbee reporting“ so far. But in the smart home app the current state can actively be requested by dragging down the room view to refresh the list. Then, the switch state, brightness level and colour is requested and displayed in the app. It is to be expected that this useful function will be provided in future firmware versions.



Manual update of the status.

**A note on Philips hue:** The Philips hue bridge/app currently supports the Zigbee 3.0 standard, but not all device types are displayed in the hue app. Only the ubisys components D1(-R), S1(-R) and S2(-R) can currently be controlled with the hue app. When and to what extent the hue app will support other ubisys products is beyond our knowledge. The ubisys gateway G1 and the components C4, D1(-R), S1(-R) and S2(-R) can control Philips hue lamps. It is possible to operate the Philips hue Bridge and the Gateway G1 within a Zigbee network.

Unfortunately, not all manufacturers provide Zigbee Over-the-Air (OTA) upgrade images, which then automatically would be integrated into your smart home system by our Gateway, just like the ubisys devices. To install new firmware, the lamps of these manufacturers have to be connected with their own gateways (e.g. the hue bridge for Philips products). After the successful update, the lamps then can be re-integrated into your smart home network.

If you want to know, whether the bridge of a third-party manufacturer can join an existing Zigbee network, it is best to contact the manufacturer. In case this is not possible, the functions of the bridge and the apps that are relying on them are not available.

## How can these lamps be integrated?

If you buy single lamps, then you just have to open the ubisys Zigbee network for new devices and connect the lamp to a power source. The lamp will then join your Zigbee network and you can assign it to a room as usual and, like any other device, integrate it into groups and scenes or bind it to a switch.

Lamps from a starter kit usually have to be restored to default settings first, because they are connected to the set's bridge. You can either use a remote controller or our USB Stick U1 with our Network Manager software. In the Network Manager, under Maintenance, section Zigbee Touchlink, you will find the command „Restore to default settings“. Please note that the distance between USB Stick and lamp should be within 10-50 cm.

## More Compatible Products



### Sensors and other Zigbee devices with

Besides the mentioned Smart Bulbs you have the option of completing the ubisys system with devices from other manufacturers: door/window contacts, smoke detectors, motion sensors, temperature/humidity sensors, brightness sensors, smart plugs, remote controls, battery-free wall switches, alarm keypads, etc.

We check compatibility and work closely with third-party manufacturers to ensure smooth interaction.

The devices can be controlled via the ubisys app and/or can be integrated into scenes, for example.



Products available in our online shop ([www.smarthome-store.de](http://www.smarthome-store.de)) have been tested for compatibility by ubisys and can easily be integrated into your ubisys system.

### Wall frame for Apple iPad

Also available in our shop are high-quality aluminium frames for the wall assembly of iPads. If you want to control your ubisys smart home system centrally via an iPad, iPad Air or iPad mini, we recommend this aluminium frame for flush wall assembly.

You can find more information in our online shop at [www.smarthome-store.de](http://www.smarthome-store.de).



## Products for Electrical Specialists and System Integrators

### **Installation and Diagnostics Tools**

For the professional user ubisys offers various installation and diagnostics tools.

# Professional Installation Network Manager



This product is primarily aimed at electrical contractors and system integrators

## Zigbee Software for Evaluation, Testing and Commissioning

With the ubisys Zigbee Network Manager, the electrician, system integrator or technically interested user can search for Zigbee networks on a PC, notebook, netbook or tablet and log into a network to perform a basic configuration, document the installation, diagnose problems, etc. A basic knowledge of the Zigbee concepts is a prerequisite for the successful use of this versatile tool.

Create bindings, set up reportings, explore the network, check settings, etc. The software also supports Zigbee devices from other manufacturers.

The program is also ideal for rapid evaluation of Zigbee components.

## Supported Function Groups (Zigbee Cluster):

<b>Network Functions</b>	<ul style="list-style-type: none"> <li>Search for Zigbee networks</li> <li>Create a new network</li> <li>Join an existing network</li> </ul>	<ul style="list-style-type: none"> <li>Leave the network</li> <li>Diagram of channel workload</li> </ul>
<b>Management (ZDO/ZDP)</b>	<ul style="list-style-type: none"> <li>Explore network</li> <li>Address solution</li> <li>Open/close network</li> <li>Create/delete bindings</li> </ul>	<ul style="list-style-type: none"> <li>Retrieve report settings</li> <li>Remove a device from the network</li> </ul>
<b>Basic Functions (Basic Cluster)</b>	<ul style="list-style-type: none"> <li>Restore default settings</li> <li>Manufacturer, model, date of manufacture</li> </ul>	<ul style="list-style-type: none"> <li>Identification</li> <li>Installation location</li> <li>Environment</li> </ul>
<b>Identification (Identify Cluster)</b>	<ul style="list-style-type: none"> <li>Allow unit to identify</li> </ul>	
<b>Groups (Groups Cluster)</b>	<ul style="list-style-type: none"> <li>Add device to a group</li> <li>Remove device from a group</li> </ul>	<ul style="list-style-type: none"> <li>Show group membership</li> </ul>
<b>Scenes (Scenes Cluster)</b>	<ul style="list-style-type: none"> <li>Number of saved scenes</li> <li>Future version: Edit scenes</li> </ul>	
<b>Switching (On/off Cluster)</b>	<ul style="list-style-type: none"> <li>Turn on</li> <li>Turn off</li> </ul>	<ul style="list-style-type: none"> <li>Switch</li> <li>Request switching state</li> </ul>
<b>Level (Level-Control Cluster)</b>	<ul style="list-style-type: none"> <li>Approach certain level</li> <li>Raise/lower</li> </ul>	<ul style="list-style-type: none"> <li>Stop</li> <li>Request level</li> </ul>
<b>Colour (Color-Control Cluster)</b>	<ul style="list-style-type: none"> <li>Set specific colour</li> <li>Request current colour</li> </ul>	
<b>Shutter Control (Window Covering Cluster)</b>	<ul style="list-style-type: none"> <li>Raise until stop</li> <li>Lower until stop</li> <li>Stop</li> <li>Target certain height (absolute, percentaged)</li> </ul>	<ul style="list-style-type: none"> <li>Adjust lamella angle (absolute, percentaged)</li> <li>Parameterizing methods</li> <li>Calibration (only ubisys devices)</li> </ul>
<b>Meter (Metering Cluster)</b>	<ul style="list-style-type: none"> <li>Total consumption</li> <li>Total yield</li> <li>Instantaneous power (received)</li> </ul>	<ul style="list-style-type: none"> <li>Instantaneous power (released)</li> </ul>

<b>Thermostat (Thermostat Cluster)</b>	<ul style="list-style-type: none"> <li>Request room and outside temperature</li> <li>Request presence state</li> <li>Request temperature ranges of heating and cooling regulators</li> <li>Request and specify limitations of the desired value ranges</li> </ul>	<ul style="list-style-type: none"> <li>Select internal or external sensors for control circuits</li> <li>Request and specify desired values both for presence and absence case for heating and cooling regulators</li> </ul>
<b>Temperature Measurement (Temperature Measurement Cluster)</b>	<ul style="list-style-type: none"> <li>Measurement value</li> <li>Measurement range</li> </ul>	<ul style="list-style-type: none"> <li>Tolerance</li> </ul>
<b>Electrical Measurement (Electrical Measurement Cluster)</b>	<ul style="list-style-type: none"> <li>Voltage</li> <li>Current</li> <li>Frequency</li> <li>Phase angle</li> </ul>	<ul style="list-style-type: none"> <li>Power factor</li> <li>Apparent power</li> <li>Active power</li> <li>Reactive power</li> </ul>
<b>Power Source (Power Configuration Cluster)</b>	<ul style="list-style-type: none"> <li>Power supply: Voltage, frequency</li> <li>Power supply: Alert threshold for both undervoltage and over-voltage</li> </ul>	<ul style="list-style-type: none"> <li>Battery: Manufacturer, type, rated capacitance, rated voltage, amount, voltage, alert threshold for undervoltage</li> </ul>
<b>Commissioning (Commissioning Cluster)</b>	<ul style="list-style-type: none"> <li>Pre-configure network key</li> <li>Change commissioning key</li> </ul>	<ul style="list-style-type: none"> <li>Set channel mask</li> <li>Set transmitting power</li> </ul>
<b>Commissioning (Touchlink Cluster)</b>	<ul style="list-style-type: none"> <li>Restore to default settings</li> </ul>	
<b>Firmware Update (OTA Upgrade Cluster)</b>	<ul style="list-style-type: none"> <li>Start an update</li> </ul>	<ul style="list-style-type: none"> <li>Display parameters</li> </ul>

## Technical Data

### Standards

Zigbee 3.0

### System requirements

- PC with x86 or x64 processor
- Windows Vista, Windows 7, Windows 8, Windows Server 2008, 2008 R2, 2012
- The Network Manager is a desktop application
- ubisys Zigbee USB Stick U1

### Item No. and Price

<b>Item No.</b>	1113
<b>Price*)</b>	<b>238.00 €</b> (Company-wide license)

\*) Price incl. 19% VAT.

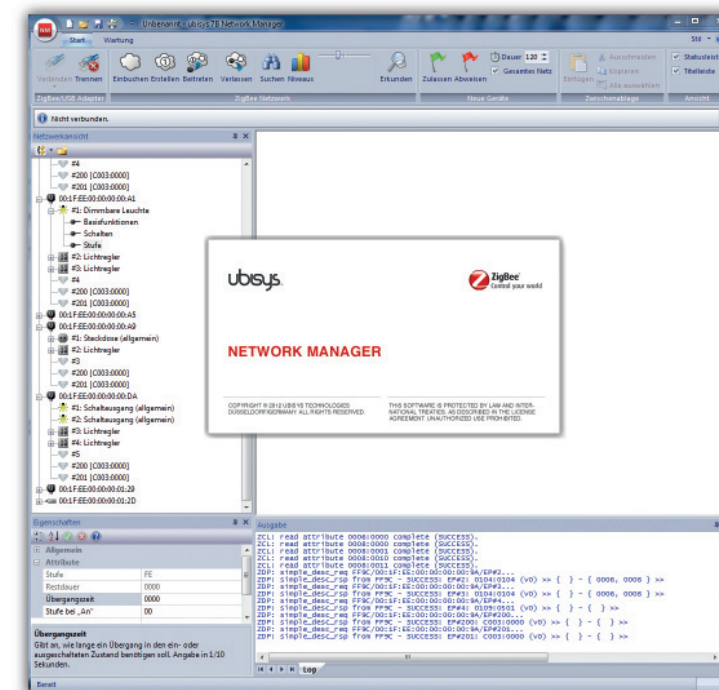

# Zigbee USB Stick U1



This product is primarily aimed at electrical contractors and system integrators

## Zigbee USB stick with integrated antenna (2.4 GHz)

This device allows notebooks, netbooks and PCs to access to IEEE 802.15.4/Zigbee radio networks.

You require this stick if you want to use ubisys Zigbee commissioning software for professional installation to set up basic configuration without a gateway during the shell construction phase.

### Technical Data

#### Features

- Zigbee Coordinator und Trust Center
- Zigbee router
- Centralized und Distributed Security

#### Standards

- IEEE 802.15.4
- Zigbee 3.0
- USB 2.0 full-speed



#### Firmware

ubisys Zigbee/USB Adapter

### Colour

Black (RAL 9005)

### Material

Plastic

### Scope of Delivery

IEEE 802.15.4/Zigbee USB Stick

#### Item No. and Price

Item No.	9072
Price*)	119.00 €

\*) Price incl. 19% VAT, plus postage and packing

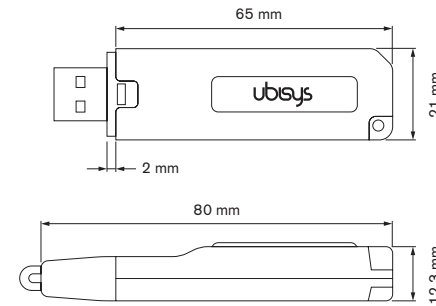

# Diagnostics IEEE 802.15.4 Wireshark USB Stick



This product is primarily aimed at system integrators

## IEEE 802.15.4 USB Stick for Wireshark with integrated antenna (2.4 GHz)

Diagnostics tool with remarkable performance for analyzing wireless IEEE 802.15.4 networks in the 2.4GHz band. Use the standard tool Wireshark™ to analyze protocols like 6lowpan, Zigbee and Zigbee PRO, as well as diagnose errors during network installation and evaluate network protocols etc.

This solution is also suitable in case you have realized own protocols based on IEEE 802.15.4 MAC and want to verify them, because Wireshark can easily be extended adding new protocols (e.g. WirelessHART, ISA100.11a etc.) by plug-ins.

High-end components such as the 32-bit ARM processor with a clock frequency of 48 MHz and 64KB SRAM as well as our own ubisys Compact15.4™ MAC implementation allows this Wireshark™ capture device enough performance reserves to analyze dense, high traffic networks – without having to discard frames due to memory shortage or lack of system performance. Especially in network-

wide broadcasts leading to a large number of packets within a short period of time, regular IEEE 802.15.4 dongles from other manufacturers will quickly reach their limits.

Due to its small size and being a USB network adapter (Microsoft® RNDIS) this stick is ideally suited for notebooks and netbooks. In contrast to solutions relying solely on ethernet interfaces, here no configuration whatsoever is needed. The channel to be surveyed is chosen with the device manager. You can also run multiple devices recording multiple channels simultaneously.

### Technical Data

#### Standards

- IEEE 802.15.4
- Zigbee 3.0
- Zigbee Green Power
- 6lowpan

#### Performance

- USB 2.0 full-speed
- ARM7, 48MHz, 64KB RAM
- 128 Frames à 127 Bytes

### Colour

Black (RAL 9005)

### Material

Plastic

#### Item No. and Price

Item No.	9010
Packaging unit	1 pc
Price*)	236.81 €
Item No.	9041
Packaging unit	16 pcs**)
Price*)	1,664.81 €

\*) All prices incl. 19% VAT., plus postage and packing

\*\*) Complete package for simultaneous recording of all 16 channels in the 2.4 GHz band. Recommended for the analysis of frequency hopping systems such as Zigbee RF4CE or detailed analysis of systems with interference-triggered channel switching such as Zigbee PRO.

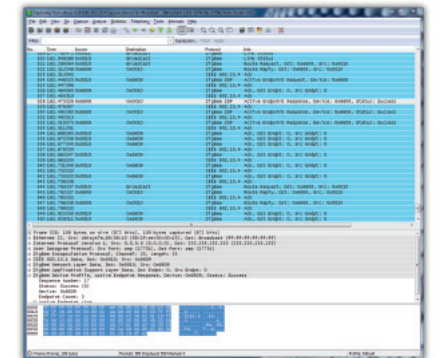
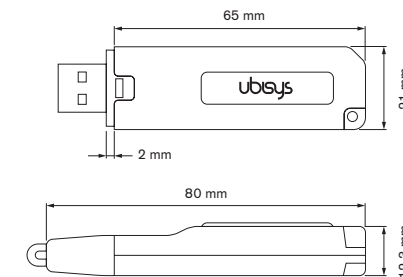



## Installation

### **Also Suitable for Retrofitting**

ubisys Smart Home primarily is a flush-mounted solution. Meaning that the components for controlling your building technology are installed in the existing switch and socket installation boxes. It does not matter which switch range you have chosen. The components can be installed behind every socket, every wall/ceiling outlet, every light switch or on a mounting rail in the control cabinet of the sub-distribution (fuse box) – regardless of the manufacturer.

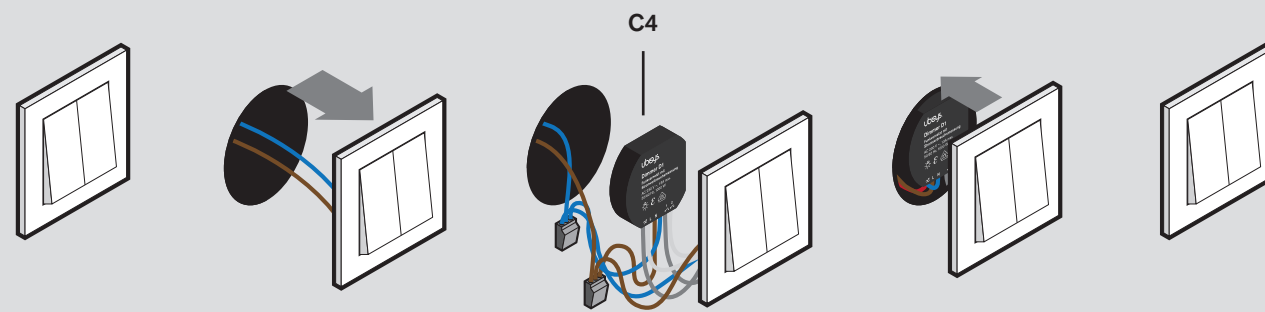
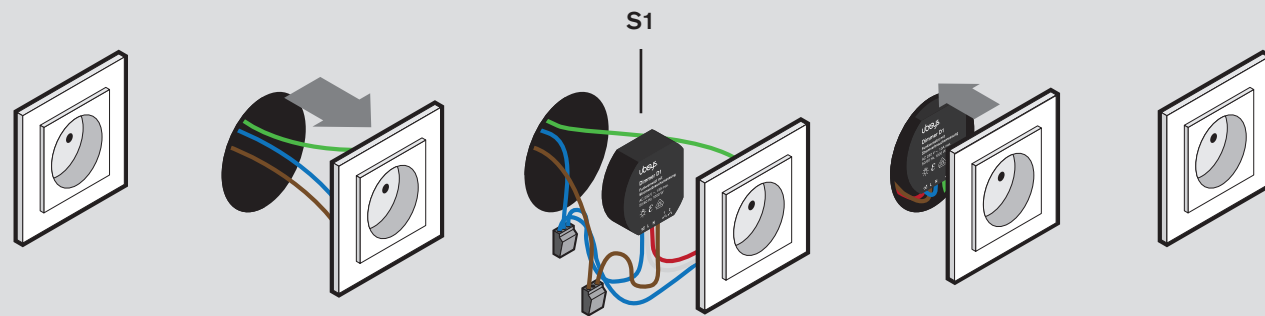
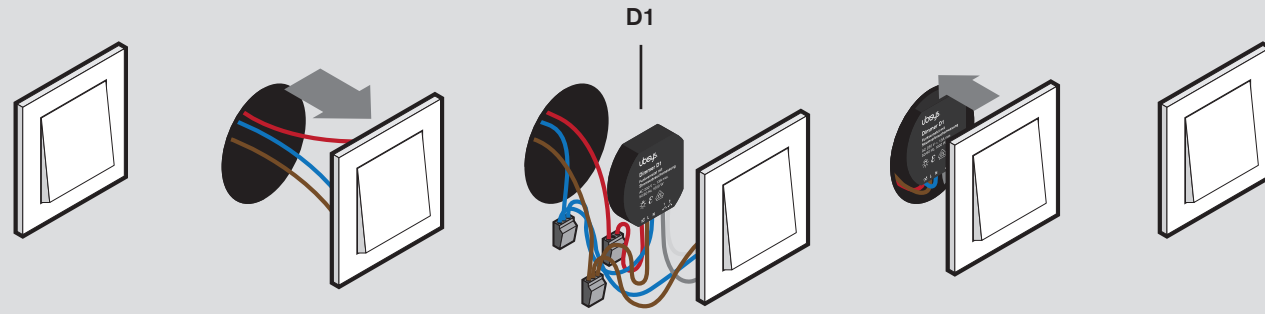

**See picture above (installation of an universal dimmer D1):**  
The universal dimmer D1 can be installed behind each light switch. The dimmer is simply connected to the existing cables via the supplied clamps.

**See picture in the middle (installation power switch S1):**  
The power switch S1 can be installed behind each outlet. Just like the dimmer and the shutter control, it is integrated into the existing cable infrastructure.

**See picture below (installation control unit C4):**  
Other control units can be supplemented at any time via the control unit C4 or wireless wall switches (see also under „Solutions/Energy-independent push-button“).

### Easy and fast installation

The ubisys Smart Home primarily is a flush-mounted solution. The components can be retrofitted – and disappear hidden away behind your switches or push buttons (see pictures). The prerequisite is that the installation boxes are sufficiently deep. Even if a box should not be deep enough, it can be deepened in the vast majority of cases retroactively. In some cases, an installation in the control cabinet of your sub-distribution is more sensible, e.g. if you want to replace an existing impulse relay.

### Keep your switches and sockets

The system from ubisys will save your investment in switches and sockets, as light or blinds can still be operated via the already installed switch – in addition to the new possibilities offered by the ubisys Smart Building solution. This leaves you independent of the manufacturer and the respective switch program. Only unconventional switches, e.g. those used in bus systems (KNX/EIB) are unsuitable.

### You save money

The uncomplicated and quick installation reduces the workload of the electrical installer you have commissioned right from the planning phase. In comparison to a bus system such as EIB/KNX-TP, infrastructure components such as power supplies, line amplifiers, line couplers or area couplers as well as the effort for their configuration are not necessary. The smart products and solutions from ubisys therefore offer you „below the line“ more performance at lower costs.

### Configuration

After installing the components, all your system needs is to be configured. This is done either via the app or our PC software. Among other things, basic settings are defined during configuration, such as:

- Designation of the rooms
- Assign components to individual rooms
- Link existing controls to any consumer (for example, a wall switch with a group of lights)
- Assignment of suitable symbols to the corresponding rooms

Furthermore, you have the option, e.g. to create scenes. Here you can create settings in advance for dimmers, blinds and other devices and then activate them by pressing a button. Example: At the push of a button, all blinds are lowered and at the same time the light dims to 50%. Scenes can quickly and easily be created, changed and deleted at any time.

You can set up your system yourself or have it carried out by an electrician. In other systems, e.g. EIB/KNX, you usually do not have this option.

**Our tip:**  
Ask your electrician for an offer including material, installation and configuration, e.g. for a comparable solution based on EIB/KNX.

**Cross- and toggle switching:**  
You can also use the universal dimmer D1 and the power switches S1/S2 in cross and alternate circuits. If you have any questions about the optimal wiring, please contact our support.

### **High-Tech Behind the Scenes.**

The smart home product line utilises the low-power wireless network standard IEEE 802.15.4 operating within the licence free 2.4 GHz frequency band together with the innovative and mature mesh networking stack with well-conceived and powerful application profile according to the Zigbee Alliance.

The radio technology used complies with international standards.

ubisys is actively involved in the development of the Zigbee standard and contributes its know-how to the design of new solutions.

To ensure that your building technology is always up to date, the devices can be easily updated during operation – without a service technician having to travel.



### Zigbee radio technology

IEEE Standard 802.15.4 defines transmission and multiple access procedures in the license-free 2.4GHz and 868/915 MHz frequency bands, which are characterized by low energy consumption at adequate data rates and ranges. The transmission power of typically 1mW is orders of magnitude lower than for mobile phones (2W) and wireless networks (100mW). The data rate is 250kbps, sufficient for all building automation tasks. Based on this, the Zigbee standard defines network protocols with intelligent routing functions and application protocols for various fields of application, such as Home Automation (predominantly private properties), Building Automation (commercial and public entities), and Smart Energy (smart utility grids) as well as other application fields. The data transmission is encrypted according to the highest security standards (AES 128), which, for example, are also approved for documents of the highest confidentiality level by government authorities. IEEE 802.15.4/Zigbee is far superior to older wireless technologies in all respects. Multi-hop routing helps to avoid connection problems, just as acknowledgment telegrams on different levels of the protocol stack make the transmission safe, robust and reliable..

With Zigbee Green Power, battery-free switches and sensors are possible, or battery-powered devices with battery lifetimes of 20 years.

### Innovative technology with many advantages

**Sustainable.** In contrast to wired, older bus installation systems, which require specially installed control cables as well as special switches and actuators (such as EIB/KNX), the radio-based system from ubisys offers the great advantage of being able to retain conventional wiring and, in addition, no new switches and sockets need to be installed.

**Budget Saving.** Starting from the planing phase installation costs are reduced dramatically. In new installments when using ubisys smart home products compared to regular bus systems such as EIB/KNX, a total cost reduction of up to 60 - 70% is possible. There also are significant savings in cabling.

**Simple.** The same applies to setting up and configuring your smart building. Save the money that it would cost to set up and configure older bus systems. No need for expert knowledge or costly hard- and software tools for a simple one-time reassignment of a switch to another end device.

**Retro-fittable.** This feature not only makes ubisys smart home ideal for new buildings but also for retro fitting solutions. Buildings can technically be brought up to date cost efficiently and without major rebuilding neccessary. The components for lights, shutters and heating in buildings can be added later and subsequently help saving costs, highten security and upgrade the property value enormously.

**Up-to-date.** By updating your firmware in the individual components they all stay up to date and keep their value permanently. This way we can provide new functions or eliminate glitches.

### Remote maintenance: First hand service and support

The ubisys gateway G1 has one particular function that backs up our service and support claims: In case of technical problems simply contact our competent support team and if absolutely neccessary allow them remote access to your gateway. No worries: The access is absolutely secure and can be terminated by yourself at any time.

### Always up to date

If you decide to use Smart Building by ubisys you will get components whose firmware can be updated via the internet at any given time. As soon as we offer new functions our customers using ubisys components immediately reap the benefits – unless of course, the update in question, is hardware based. Our home gateway regularly checks for ubisys latest firmware. You then decide if you want it automatically installed or maybe wait for an even newer version. The gateway also checks up on updates for all other Zigbee components in your system and makes it available. Via „Zigbee Over-the-Air firmware upgrade (OTA)“ these kind of devices can be upgraded while still active within the system – thus eliminating the need of a service engineer showing up or, god forbid, having to deinstall the device and sending it back for servicing.

## Quality Claim and Privacy

### **Quality and Your Privacy are Important to Us**

ubisys products are „Made in Germany“. We develop Smart Home components with the highest quality standards.

Data protection also plays a significant role for us. The ubisys Smart Home platform is not a cloud based solution. Your data is only stored on the Gateway G1.



# Quality Claim and Privacy



## Highest quality standards and „Made in Germany“

The quality concept is firmly anchored in our company philosophy. ubisys products are „Made in Germany“. The implementation and production of our high-quality smart home components takes place in Germany. The development of our products takes place completely in-house, so that we always are 100% in control and the components meet our quality requirements at all times.

ubisys developments are based on bundled expert know-how. They are the result of years of experience in dealing with innovative technologies. Experience shared by users of our products – both B2C and B2B – all over the world.

## Privacy guaranteed

Unlike other smart home providers, the ubisys platform is not cloud-based. The data of your system remains completely on your ubisys G1 gateway and never will be transferred to the cloud<sup>1)</sup>. This guarantees the protection of your privacy.

Your system runs independently on the local network, ensuring high reliability and fast response times. An internet connection is only necessary for push messages and controlling while on the go. Even when on the move, the app always establishes a direct connection to the gateway – without going through the cloud. Your data is protected at all times.

<sup>1)</sup> Except push notifications sent via Apple and Google News Services.

## Show House

### **Show House for Smart Home Applications**

In cooperation with the architectural office „atelier | rheinruhr“, ubisys operates a show house for Smart Home applications. This residential and commercial building offers its users maximum flexibility, security and comfort.

Here you can experience ubisys products in daily use and let a guided tour demonstrate the various solutions to you.





Architecturally, the show house impresses with its clear lines and high-quality materials. Equipped with the innovative products from ubisys, it represents a perfect example of timeless architecture in combination with future-oriented building technology.



### ubisys Smart Home live experience

In the show house you have the opportunity to experience all current ubisys products live. Test for yourself the user-friendliness of our system and learn everything about the installation of the components.

The first components (dimmer, blind control) were already installed in October 2009 and have been working successfully in daily use ever since.

### Future-proof

By using wireless transmission technology, it is also equipped for future expansion.

Applications can be added or changed at any time without problems and without great effort.

### Visitation

Would you like to get a detailed impression of our products and their advantages? Simply contact us and arrange a viewing appointment today.

The show house is located at Revierstrasse 17, 46145 Oberhausen, Germany.

### Contact

atelier | rheinruhr  
Revierstraße 17  
46145 Oberhausen  
Germany

For questions:  
T: +49. 211. 54 21 55 - 00  
E: info@ubisys.de

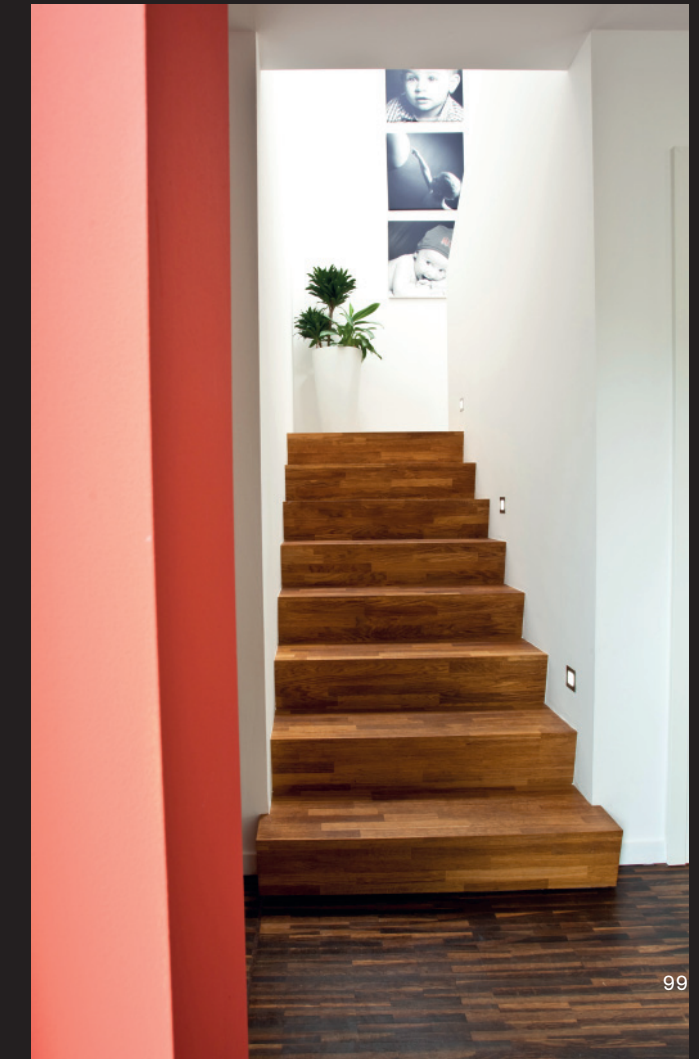
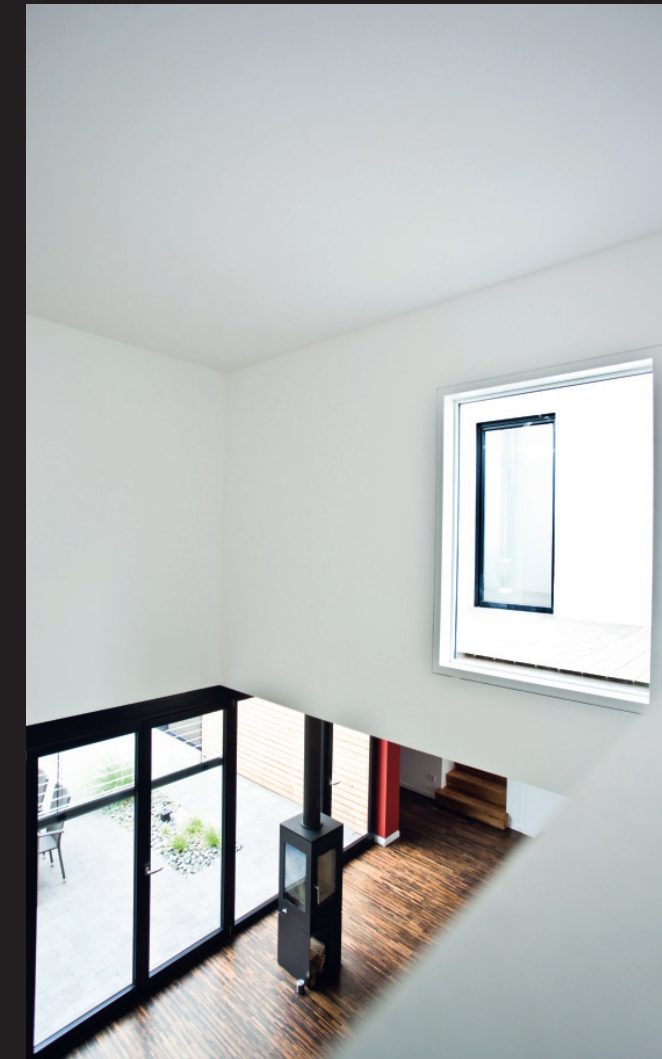

## Sources of Supply and Contact

### **Electrician**

ubisys Smart Home products are available directly from ubisys and from electrical retailers. Our sales network with all associated partners is constantly being expanded – just ask your electrical installer.

### **Online Shop**

The easiest way to buy our Smart Home products is in our online shop: **[www.smarthome-store.de](http://www.smarthome-store.de)**. The shop is for end customers and resellers alike. After authorization resellers can get special access to receive discounts.

### **Contact**

ubisys technologies GmbH  
Neumannstr. 10  
40235 Düsseldorf  
Germany

T: +49. 211. 54 21 55 - 00  
F: +49. 211. 54 21 55 - 99

[info@ubisys.de](mailto:info@ubisys.de)  
[www.ubisys.de](http://www.ubisys.de)

**Online shop:**  
[www.smarthome-store.de](http://www.smarthome-store.de)

# Imprint

## **Publisher**

ubisys technologies GmbH  
Neumannstr. 10  
40235 Düsseldorf  
Germany

## **Concept and design**

ubisys

## **Picture credits**

ubisys, atelier | rheinruhr, basalte,  
Adobe Stock

We reserve the right to make changes  
in technology and design. Printing-  
related color deviations can not be  
excluded.





ubisys technologies GmbH  
Neumannstr. 10  
40235 Düsseldorf  
Germany

T: +49. 211. 54 21 55 - 00  
F: +49. 211. 54 21 55 - 99

info@ubisys.de  
www.ubisys.de

Online shop:  
www.smarthome-store.de

® ubisys technologies GmbH.  
All rights reserved.